

ESSE

1000 W
Heat Storage Range Cooker

Instruction Manual

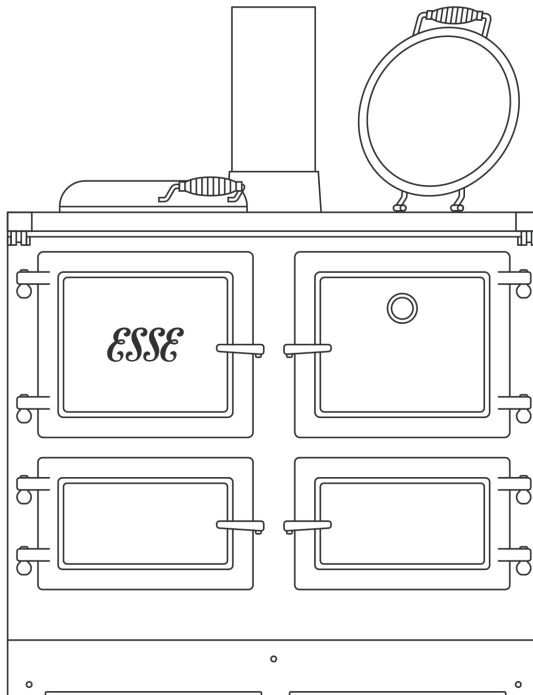

1000 WN & 1000 WD Installation & Commissioning Instructions

STATUTORY WARNINGS

Please read these instructions carefully for full information on the safe installation, use and care of your new ESSE appliance.

We cannot accept responsibility for damage to persons or items due to poor or incorrect installation of this appliance.

In the UK, the installer has a responsibility under the Health and Safety at Work Act 1974 to provide for the safety of persons carrying out the installation. Attention is drawn to the fact that fire cement is caustic and hands must be washed thoroughly after use. The appliance is heavy (max 315kg) and care must be taken during handling. Although the appliance does not contain asbestos products, it is possible that asbestos may be disturbed in existing installations and every precaution must be taken.

These instructions give a guide for the installation of the appliance but in no way absolve the installer from responsibilities to conform to AS/NZS Standards, in particular AS/NZS2918:2018, relating to the installation of solid fuel appliances. All local regulations including those referring to national standards need to be complied when installing this appliance.

Outside of the UK, the installer must comply with all local, national & European standards that apply.

Any adjacent combustible material should be far enough away from the appliance so as not to raise 60°C above the room temperature when the appliance is in operation. If necessary, any adjoining walls should be protected from the effects of heat.

Clearances from combustible materials are:

- Rear clearance of 175mm with heat shield.
- Side clearance of 20mm below the hob/100mm above the hob.

It is also recommended that a smoke alarm and appropriate fire safety equipment such as a fire extinguisher and fire blanket are installed in the kitchen as a safety precaution.

An adequate air supply for combustion and ventilation is required. A purpose provided air vent is necessary. Air openings provided for this purpose must not be restricted.

This appliance must be correctly installed in accordance with the manufacturer's instructions by a suitably qualified person.

ESSE does not accept responsibility for damage to persons or items resulting from poor or incorrect installation of this appliance.

Do not let children near the oven during use to avoid the danger of burns or injury. Use of the appliance by the elderly or infirm should be supervised.

Due to our policy of continuous innovation, we reserve the right to adjust or modify our product without prior notification.



**THIS APPLIANCE IS NOT SUITABLE FOR INSTALLATION
IN A SHARED FLUE SYSTEM**

TECHNICAL INFORMATION

Nominal heat output	5.0kW
Combustion air requirements	29m ³ /h
Weight of the appliance	315kg
Minimum chimney draught	12Pa
Maximum chimney draught	25Pa
Mean flue gas temperature	170°C
Tested net efficiency	81.0%
Energy class	A+
Energy index	113
Seasonal efficiency	75.2%

The cooker data plate is located on the inner door panel of the bottom right hand oven.

FIGURE 1: 1000 W COOKER DIMENSIONS

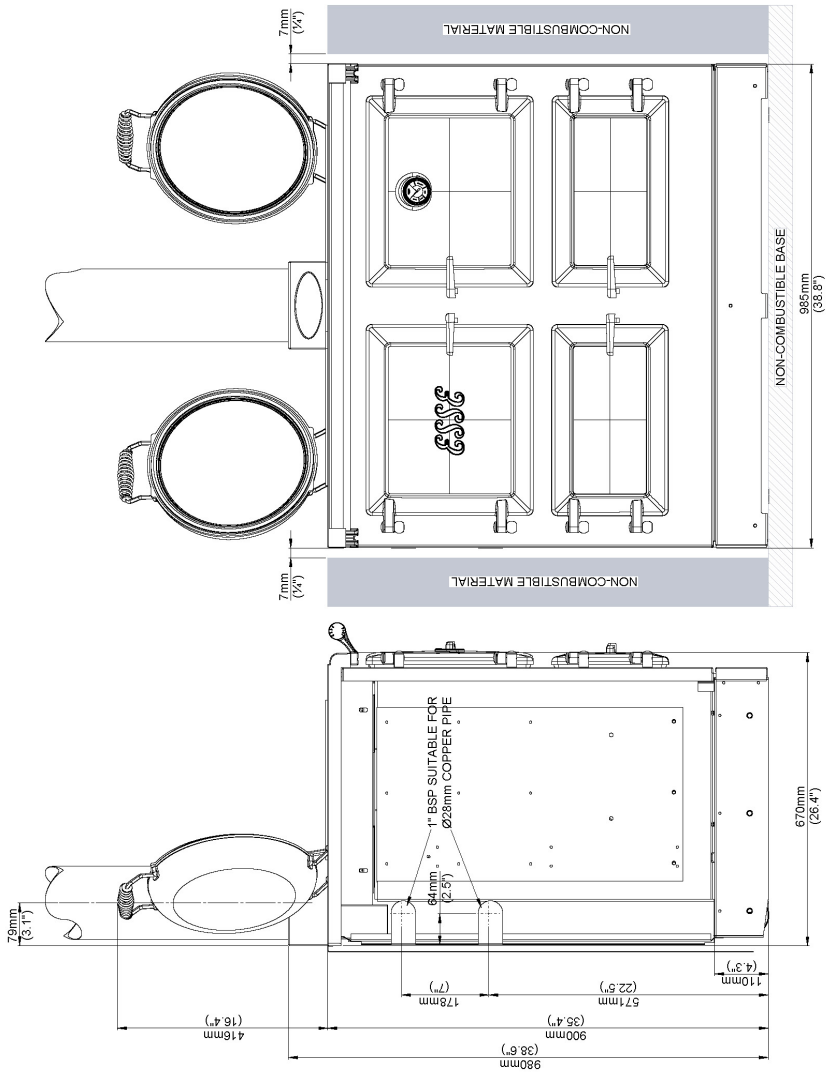

CHIMNEY & FLUE INFORMATION

The successful operation of the cooking appliance relies on the adequate performance of the chimney to which it is connected. The following chimney guidelines must be followed:

- It should be installed in accordance with AS/NZS 2918:2018
- It should have an internal cross section of no less than 320cm² (200mm dia.) (If a flue liner is used, it should be 150mm (6'') diameter and be made of suitable material for burning wood). The flue diameter is 150mm (6'').
- Voids in the chimney should be avoided, as these will prevent a steady flue draught. The appliance flue pipe should pass beyond the narrowing of the chimney.
- The flue needs to be a minimum of 4.6m in height and terminate in accordance with AS/NZS2918
- If the appliance is installed as a freestanding appliance, it should not support any part of the chimney.
- Be free from cracks, severe bends, voids, and obstructions.
- Be connected to this one appliance only.
- New chimneys must be in accordance with local regulations.
- The chimney must be capped to prevent ingress of rain.
- A flue/chimney access point may also be required so that the state of the chimney can be checked and any fallen soot removed.
- External flues must be insulated to prevent heat loss.
- Do not fit an extractor fan in the same room as the appliance.
- Be a minimum 4.6m high from top of the flue box to the chimney pot.



The chimney/flue to which this appliance is being connected must be swept and examined for soundness prior to installation. Remedial action should be taken if required, seeking expert advice if necessary. Where the chimney is believed to have served an open fire installation it is possible that a higher flue gas temperature from a closed appliance may loosen deposits that were firmly adhered, with the consequent risk of flue blockage. It is therefore recommended that the chimney be swept a second time within a month of regular use after

The chimney can be checked, before the appliance is installed, with a smoke match. If the chimney doesn't pull the smoke it may suggest the chimney needs attention.



This test is only a guide as an apparently poor flue may improve once the appliance is installed, lit and the flue is warmed. If, once the appliance is installed there is any doubt that the chimney is providing an adequate draught, a flue draught reading should be taken.

FIGURE 2: CHIMNEY & FLUE PERFORMANCE

1) Pressure and suction zones created by wind

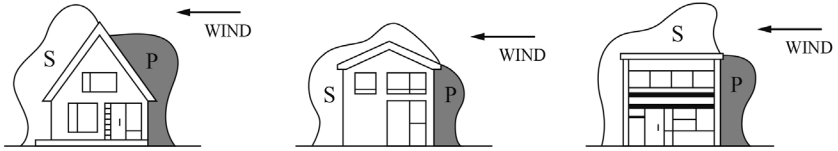

2) The position of chimney outlets

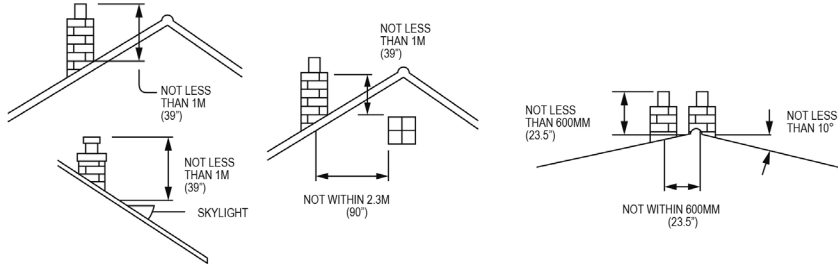

3) Potential causes of down draught

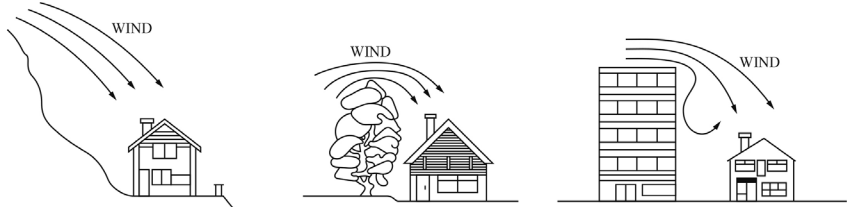

LOW FLUE DRAUGHT SYMPTOMS: DIFFICULT TO LIGHT AND SMOKE COMING INTO THE ROOM	
CAUSE	REMEDY
Cold chimney.	Line the chimney.
Chimney too short.	Extend the chimney.
Down draught.	Relocate/extend chimney terminal. Fit an anti-down draught cowl.
Chimney diameter too large.	Line the chimney.
Chimney obstruction.	Clear/sweep the chimney.
Restricted air supply.	Check for competing draughts (other chimneys, extractor hood/fans). Fit an air vent if the room is sealed.
HIGH FLUE DRAUGHT SYMPTOMS: FIRE DIFFICULT TO CONTROL, FUEL WILL NOT LAST, COOKER TOO HOT, APPLIANCE DAMANCE, AND CHIMNEY FIRE	
External wind conditinas combined with chimney terminal.	Fit stabiliser cowl. Fit flue draught stabiliser.

FIGURE 3: VALLEY DEFAULT FLUE KIT

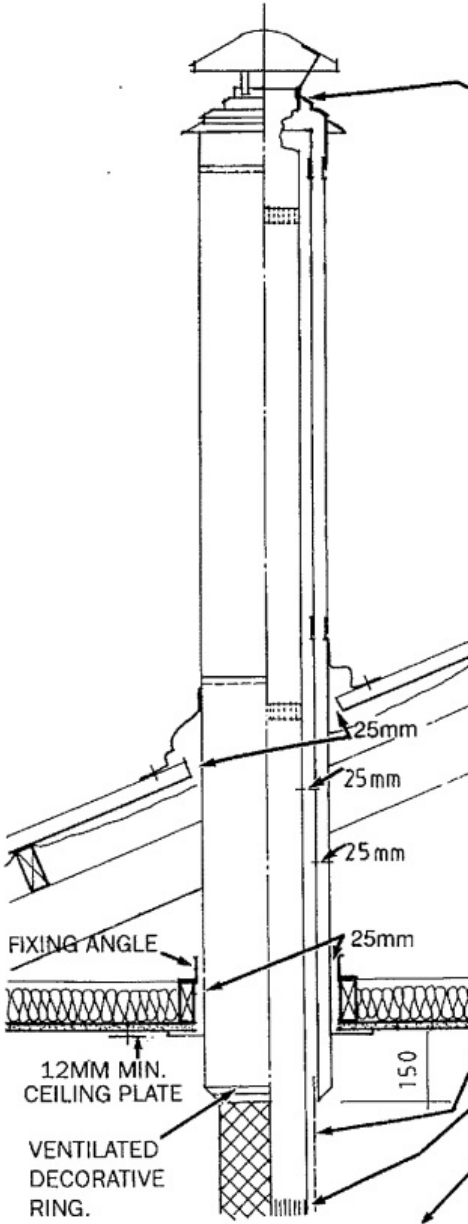

TRIPLE SKIN COWL.

COWL SLEEVE TO FIT INTO 6" S.S. OUTER GALVANIZED SLEEVE TO FIT OVER 10 1/4 GALVANIZED CASING FIXED WITH 3 SCREWS. SCREWS OR POP RIVETS ARE NOT SUPPLIED WITH FLUE KIT.

DIMENSIONS.

S.S. CASING	FLUE	152	6"
GAL. CASING	INNER	209mm	8 1/4"
GAL. CASING	OUTER	260mm	10 1/4"
PERFORATED CASING		200mm	7 7/8"

ROOF FLASHING NOT SUPPLIED WITH FLUE KIT.

10 1/4" 8 1/4" GALVANIZED CASINGS TO BE SEPARATED WITH CLIPS. CRIMPED END FACING UP.

PERFORATED CASING 7 7/8"

6" S.S. FLUE CRIMP INTO HEATER.

LOCATING RING ON HEATER TO LOCATE PERFORATED CASING.

FIXING ANGLE

12MM MIN. CEILING PLATE

VENTILATED DECORATIVE RING.

25mm

25mm

25mm

25mm

150

UNPACKAGING YOUR NEW COOKER

Unpack your new ESSE Cooker, removing all of the outer packing and accessories from the top and bottom ovens, including protective film on the door liners. At this time please examine the cooker for any damage to the finish and hob.

Any damage to the cooker or anything missing, please contact your supplier for advice.

We ask that you dispose of any packaging in a safe, responsible manner and recycle where possible.

COMMISSIONING CHECKLIST

To assist with any potential guarantee claim please complete the following information:

To be completed by the installer.

Dealer the appliance was purchased from:
Name:
Address:
Telephone Number:
ESSENTIAL information:
Date Installed:
Model Description:
Serial Number:
Installation Engineer:
Company Name:
Address:
Telephone Number:

Commissioning Checks - to be completed and signed:

Is the flue system correct for this appliance?	YES	<input type="checkbox"/>	NO	<input type="checkbox"/>
Flue swept and checked for soundness?	YES	<input type="checkbox"/>	NO	<input type="checkbox"/>
Smoke test completed on installed appliance?	YES	<input type="checkbox"/>	NO	<input type="checkbox"/>
Spillage test complete?	YES	<input type="checkbox"/>	NO	<input type="checkbox"/>
Has the use of the appliance and controls been explained?	YES	<input type="checkbox"/>	NO	<input type="checkbox"/>
Clearance to combustible materials checked?	YES	<input type="checkbox"/>	NO	<input type="checkbox"/>
Instruction book handed to customer?	YES	<input type="checkbox"/>	NO	<input type="checkbox"/>
CO Alarm fitted?	YES	<input type="checkbox"/>	NO	<input type="checkbox"/>

Signature.....

Print Name.....

FIGURE 4: MINIMUM CLEARANCES FOR THE ESSE 1000 WOOD APPLIANCE INSTALLED WITH A VALLEY DEFAULT FLUE KIT WITH A REAR 900mm X 180° REFLECTIVE REAR FLUE SHIELD.

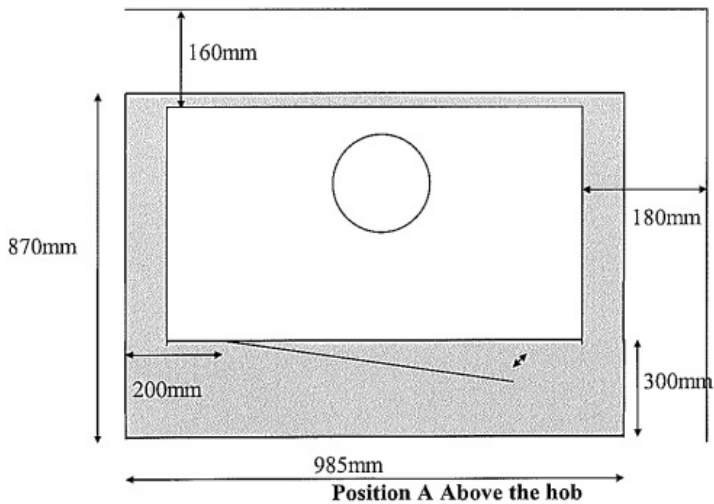

The floor protector consisted of 6mm thick cement fibre sheet which had a thermal resistance of $0.8\text{m}^2\text{K/W}$, per 4mm thick sheet

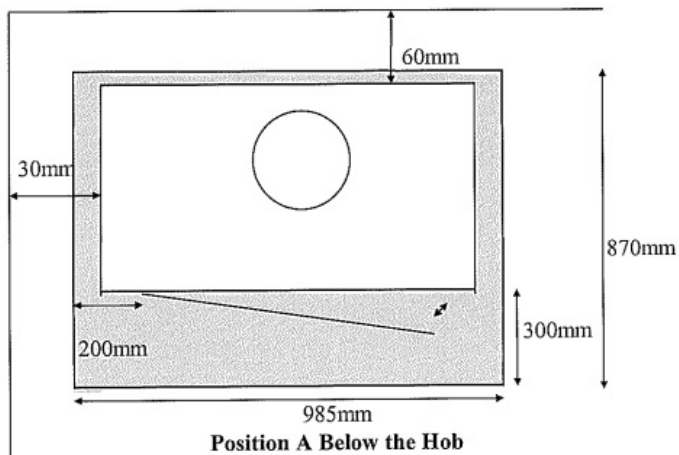

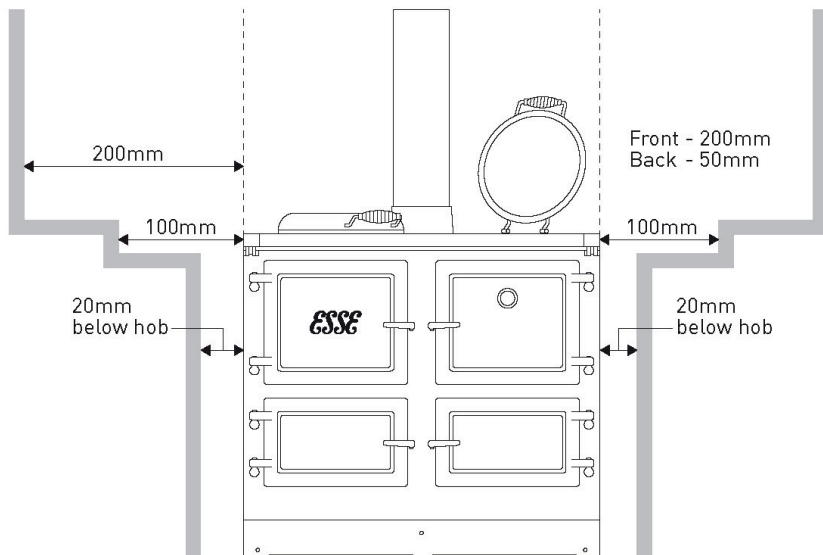

CLEARANCE TO COMBUSTIBLES

Side wall below cooking level	20mm
Side wall at cooking level	100mm
Side wall above cooking level	200mm
Back wall	50mm
Floor in front of appliance	200mm
Front	1000mm

The appliance must be placed on a non-combustible floor

INSTALLATION

You must be aware of the following safety requirements & regulations:

This appliance shall be installed in accordance with the regulations in force.

Read the instructions before installing or using this appliance.

The cooker must be installed in accordance with: All relevant AZ/NZS Standards / Codes of Practice and the relevant Building / IEE regulations

Location of the Oven

This appliance is designed for domestic cooking only. Use for any other purpose could invalidate any warranty or liability claim.

The cooker weighs approximately 315kg and so the floor must be capable of withstanding the load.

Make sure the cooker is level, use packing pieces if necessary.



Before using your cooker remove plastic protective covers from inner door panels; lift up lids and hinge covers.

Flue Connection

The flue pipe used to connect the appliance to the chimney is 6" (150mm) in diameter.

The flue connection is on the top of the appliance, in the centre at the back.

Important Installation Notes

1. The installation must allow access for adequate chimney sweeping and flue cleaning.
2. Avoid using bends greater than 45° to the vertical. All flue pipe sections should be as close to the vertical as possible.
3. All joints in the flue system must be effectively sealed.
4. All flue sockets must face upwards. On completing the installation of the appliance, the chimney, hearth and walls adjacent to the cooker must conform to local or national regulations currently in force. (AS/NZS 219:2018)
5. Air inlet grilles should be positioned so that they are not liable to blockage.
6. An air extraction device shall not be used in the same room as the appliance unless adequate additional ventilation is provided.
7. A flue cleaning door should be fitted to provide access for cleaning the flue and chimney.
8. Check the appliance for soundness of seals between casing and main components and that all supplied parts and fittings are correctly fitted.
9. Ensure the appliance is left operational and hand over the operating instructions and operating tools supplied.
10. Before leaving the installation demonstrate the operation of the appliance to the user. Explain all controls and flue way access for cleaning.

Placing the cooker

The 1000 W can be lifted from the pallet it is delivered on utilising ESSE lifting wheels issued to ESSE retailers. These allow the cooker to be wheeled into position in the home. Once decoupled from these wheels and on a flat floor, the cooker can be gently moved backwards by removing the kick strip & fitting one set of wheels to the front to lift the cooker, so it can then be pushed back towards the wall using the built in rollers. In the base of the cooker at each side at the rear; push on the front of the top casing but not the towel rail. Do not use the towel rail or the bolster lid handles as a lifting rail as damage will occur.

Positioning

The appliance should be sited on non-combustible material.

FLUE DRAUGHT TEST

- Measure and record flue draught.
- Check Ventilation,
- Check no extractor fan, other appliance or other flue interferes.
- With D model, check plumbing circuit



This test is only a guide as an apparently poor flue may improve once the appliance is installed, lit and the flue is warmed. If, once the appliance is installed there is any doubt that the chimney is providing adequate draught, a flue draught reading should be taken.

Flue Draught Readings

Two flue draught readings should be taken, one with the appliance at minimum firing rate and one at maximum firing rate. To test the flue draught, remove the flue box door and fit the flue draught test plate supplied with the cooker. A flue draft gauge can now be fitted and the test performed.

Minimum reading: The appliance should be lit and allowed to warm the flue thoroughly. Close the air slider control and ensure firebox door is fully closed. Allow the burning rate to become steady. The flue draught reading should now be taken; the minimum required is 12 Pascal's [Pa] (0.05" wg.).

Maximum reading: The air slider controls can now be opened to allow the appliance to burn at maximum rate. Keep the flue box door closed. Take a flue draught reading.

Ideally, the flue draught readings should range between 12Pa, 0.12mm (0.05" wg.) and 24Pa, 2.5mm (0.1" wg.). Any readings significantly outside this range may indicate the need for remedial action. Low flue draught symptoms: difficult to light and smoke coming into the room. With a high flue draught, fuel burns away very quickly.

Flue Stabiliser

A flue stabiliser can be fitted to reduce the draught through the appliance if the draught is too high. The flue stabiliser should be fitted in the same room as the appliance and be the same size as the flue pipe. **(Note: extra ventilation will be required as stated in the Building Regulations).**

HOT WATER SYSTEM

- A. There are two connections, both 1" BSP Female on the left hand side. General notes follow below.
- B. The D boiler is of stainless steel construction for use on an open vented direct or indirect system.

General Notes on Water Systems:

1. The cooker will produce hot water at differing rates depending on how it is operated. Heating control is manual, no thermostat is fitted.
2. The system must be designed to cope with loads between the maximum and minimum output. There must be sufficient gravity load to absorb 1.4 Kw for periods when the oven is being used for cooking, e.g. Domestic hot water plus gravity operated (heat leak) radiator.
3. A storage cylinder is essential for domestic hot water supply, irrespective of whether the water supply is hard or soft. A minimum cylinder capacity of 136 litres (30 gallons) is required. The cylinder should be as close to cooker as possible and not below the height of the boiler.
4. To avoid trapping air in the boiler a 1" BSP connection must be used on the flow and return tapping, and any reduction in pipe size thereafter being made on a vertical rising pipe. The cooker must be level when fitted and the flow pipe must rise from the boiler. A drain cock must be fitted on the lowest point of the return pipe and a vent to atmosphere at the highest point of each circuit. Flow pipe must rise 1 metre vertical before any change in direction.
5. The cylinder and pipe work should be lagged to avoid heat loss.
6. The static head must not exceed 60 feet of water.
7. A drain cock should be fitted to the lowest part of the circuit.
8. The total water capacity of the boiler is 3 litres.
9. A heat leak radiator should be fitted to absorb any excess heat that may be produced.

1000 WN & 1000 WD Operation Instructions

SAFETY NOTES

Please refer to Installation section of this manual to ensure appliance has been correctly installed and is connected to a suitable flue. Failure to do so will seriously inhibit the cooker's performance and could be potentially fatal.

Properly installed, operated and maintained, this appliance will not emit fumes into the dwelling. However occasional fumes from deashing and re-fuelling may occur. Persistent fume emission is potentially dangerous and must not be tolerated. If the fume emission persists, please open doors and windows to ventilate the room. Let the fire burn out or eject and safely dispose of fuel from the appliance. Once the fire is cold, check the flue and chimney for blockages and clean if required. Do not attempt to relight the fire until the cause of the fume emission has been identified and corrected. Seek expert advice if necessary.

An adequate air supply for combustion and ventilation is essential. Air openings provided for this purpose must not be restricted. Also if simultaneous operation of other heating appliances is required within the kitchen ensure that there is sufficient ventilation. Should it be likely that children, aged or infirm people approach the appliance whilst the fire door is open then a fireguard should be utilised. Also warn children not to sit or stand on the appliance or use it as a stool or step to access cupboards or shelves above the appliance.

Avoid the use of aerosol sprays in the vicinity of the cooker when it is in operation and do not heat any unopened airtight containers.

Ensure that precautions are taken when deep fat frying, never leave the appliance unattended and ensure you have fire safety equipment available such as a fire blanket in case of emergency.

When operating the cooking stove use the tools provided and follow these instructions carefully.

Always use the glove provided when opening and closing doors, as handles and surfaces will be hot.

Take care when hanging towels etc. from the rail, particularly in front of the firebox. The outer door should generally remain closed for safety.

Do not let children near the oven during use to avoid the danger of burns or injury. Use of the appliance by the elderly or infirm should be supervised



The appliance and its accessible parts become hot during use. Care should be taken to avoid touching hot surfaces. Children less than 8 years of age shall be kept away unless continuously supervised.



Unattended cooking on a hob with fat or oil can be dangerous and may result in fire, NEVER try to extinguish a fire with water, instead cover the flame with a lid or use a fire blanket.



Danger of fire: do not store items on the cooking surfaces.

INTRODUCTION

Your ESSE 1000 W is a combination appliance providing a hot plate, 3 ovens of different temperatures, room heat and in the case of the WD model domestic hot water. The firebox behind the top left door has an inner glass door for viewing the fire, which also houses the air controls.

The hinged hob covers are referred to as bolster lids. They are designed to reduce heat losses from the hotplate and therefore fuel use from the appliance when not cooking, or conserve higher hotplate temperatures for when cooking is required.

Note: The hotplates do not need to form an airtight seal to conserve heat.

BEFORE USING YOUR COOKER

Ensure that any plastic film used to protect surfaces has been removed from the bolster lids and from the inside of oven doors. The hotplate has been coated with oil at the factory to prevent rusting and therefore will require wiping with a damp cloth and drying with a tea towel or kitchen roll.

Recoat the hotplate with cooking oil occasionally to prevent cooking debris becoming difficult to remove.

LIGHTING AND CONTROLLING THE COOKER

Open flue damper by moving the lever away from you.

The damper has only 2 positions, open and closed.

FIGURE 5: FLUE DAMPER CONTROLS

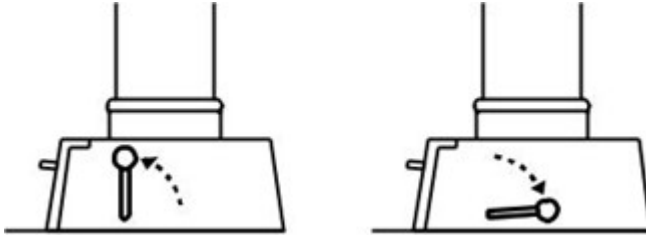

Open the outer cast iron door to reveal the glass door and set primary and ignition air controls to open position.

FIGURE 6: INNER FIRE DOOR AND AIR CONTROLS

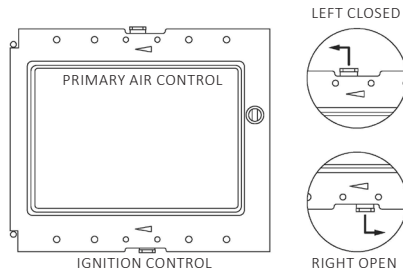

Open the glass door and set the fire using rolled up paper, on top of which small sticks of dry kindling wood has been placed. Light the fire and depending on how well the chimney is pulling, close or partially close the glass door until the kindling is well alight.

Reload the fire with small logs. You may experience smoke back out of the firebox when reloading as the chimney may still be in the process of warming up.

Allow the fuel to start to burn and when appropriate continue to refuel, building up the size of the firebed. When refuelling is required, open the glass door slowly to minimise the risk of smoke and flames escaping. Once the fire is well established, close the flue damper by moving the lever towards you.

Burning wood; set the controls to the desired rate. It is recommended the ignition control is closed once the fire is established and stable, using the primary control to regulate the burning rate. Care must be taken not to close the inner glass door

against any logs protruding from the fire or attempt to use the door to force any logs into the firebox as damage to the glass or firebricks can occur.

Your cooker should not be used as an incinerator and only recommended fuels are to be used.

COOKING ON THE HOTPLATE

The hotplate is a heavy iron casting, machined flat on the cooking surface. Heat up from cold or low can be achieved quite quickly with a fast burning fire. Leave the bolster lids down to allow the hotplate to warm up. Once hot, the hotplate will retain temperature for long periods even as the fire burns down. Please refer to the table for comparable temperature guides in degrees Centigrade.

Machined base pans are essential, (ask for our pans leaflet) as heat passes by conduction. Wipe the hotplate regularly to remove anything that might interfere with the contact between the hotplate and the base of the pan.

The hotplate is hottest to the left, over the fire, the temperature decreasing towards the right. Always keep the bolster lids down when not using the hotplate.

Food may be cooked directly on the hotplate, for example griddle scones, burgers, steaks, Welsh rarebit and eggs can be cooked on the hotplate with the lid closed to cook evenly, and similarly bread may be toasted under the bolster lid... Bake-o-lite paper is useful to ensure the hotplate remains clean in such instances.

COOKING IN THE OVENS

The cooker has three ovens and two hotplates. Please refer to the table for comparable temperature guides in degrees Centigrade.

Note: This is an illustrative guide. Temperatures and timings will change depending on flue and moisture content and wood quality.

FIGURE 7A: TEMPERATURE GUIDE FOR OVENS AND HOTPLATES.

	1: MAIN OVEN	2: BOTTOM OVEN	3: FIREBOX OVEN	4: HOTPLATE (HOTTEST)	5: HOTPLATE (COOLEST)
1 HOUR FROM LIGHTING	200°C	120°C	190°C	400°C	140°C
NORMAL RUNNING	200°C	140°C	250°C	320°C	220°C

Temperatures given are approximate and based on refuelling good quality seasoned wood at approximately 1.4per kg hour. To increase oven temperatures, refuel the cooker and increase the burning rate of the fuel by use of the primary and secondary air controls, and regulate to the desired temperature. Opening the flue damper will allow heat to pass directly to the chimney via the left side of the hotplate, useful for boosting the hotplate temperature without increasing the main oven temperature if required. The temperature dial on the main oven door provides an indication of the oven temperature (See Fig.16) and by comparison the temperature of the adjacent ovens. Since the dial is in the door, the thermometer will register a lower temperature when the door is opened although the oven itself will not lose temperature as quickly. The dial can take a short time to register the correct temperature once the door is again closed.

FIGURE 7B: COOKER LAYOUT

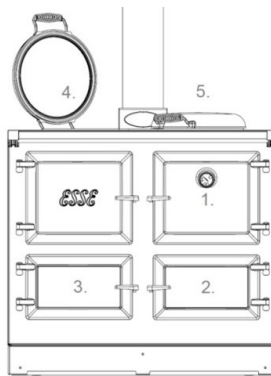

The ovens are all of equal depth and each is equipped with wire shelves which can be set to the desired height. The shelves have anti-pull out stops on their ends to prevent them from being pulled out inadvertently; to remove a shelf, pull forward until the stop is reached, then lift at the front and pull out of the oven. Use reverse procedure to refit. If the shelves pull straight out then they are in back to front!

FIGURE 8: REPOSITIONING THE WIRE SHELF.

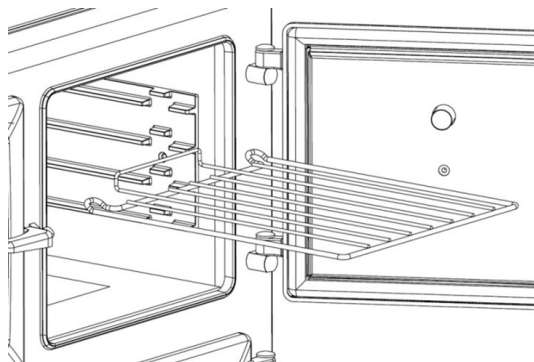

FIGURE 9: THERMODIAL AND APPROXIMATE TEMPERATURES.

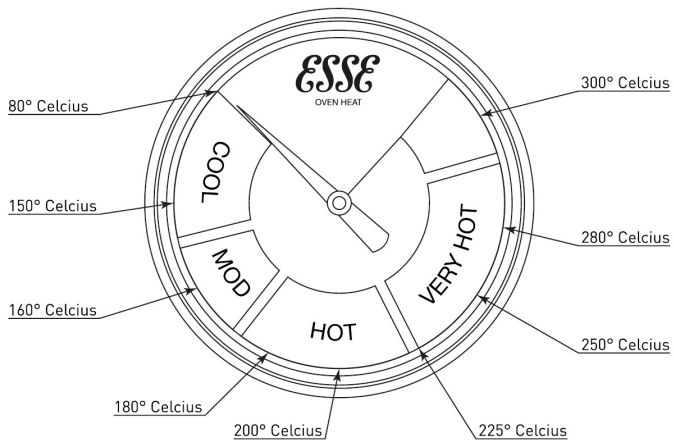
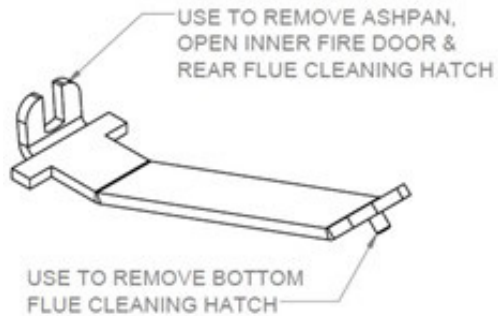

FIGURE 10: COOKER TOOL



ASH REMOVAL

When burning wood, only remove small amounts of ash from the grate, leaving ideally 30mm depth of ash in the bottom for best performance.

TYPES OF FUEL

Seasoning and storing firewood.

Wood, which has recently been cut and is still full of sap and moisture is known as "green" wood.

Greenwood will generally burn poorly and inefficiently, because it can have over 50% water in its cells. It may be hard to light, smoulder, not put out any heat and cause more than the usual amount of creosote to build up in your chimney.

So your aim should be to dry the wood out to below 20% moisture content, this process is called seasoning. As the name implies, you should store your wood for a season or so, while it dries, but there are things you can do to speed up seasoning by cutting the wood earlier, rather than just before you use it.

Wood is composed of bundles of microscopic tubes that were used to transport water from the roots of the tree to the leaves. These tubes will stay full of water for years even after a tree is dead. This is why it is so important to have your firewood cut to length for 6 months or more before you burn it, it gives this water a chance to evaporate since the tube ends are finally open and the water only has to migrate a foot or two to escape. Splitting the wood helps too by exposing more surface area to the sun and wind, but cutting the wood to shorter lengths is of primary importance.

Here's how you can tell whether your wood is ready or not. Well-seasoned firewood generally has darkened ends with radial cracks or splits visible, it is relatively lightweight, and makes a clear "clunk" when two pieces are beat together. Green wood on the other hand is very heavy, the ends look fresher, and it tends to make a dull "thud" when struck.

Another thing you can do to help is store your wood properly. Store it off the ground by building the pile on some longer logs (or whatever method you can devise). A shed or shelter with an open side makes an ideal storage place, as the air can circulate around the logs and help to dry them out. Unventilated spaces or plastic tarps, which never get taken off will prevent the drying and evaporation process and cause moulds and rot. So, if a tarp is your only option, take it off frequently to air the wood on fine days. And remember to put it back on again. Seasoned firewood will reabsorb large amounts of water if exposed to rain, snow and excessive dew, which is liable to make it rot and be unfit for making a good fire.

When you build up a store of firewood, remember that the wood may start to deteriorate after 4 to 5 years, although this is of course variable and depending on storage conditions and species involved.

THE WOOD BURNING PROCESS

Understanding what happens when wood is burnt will enable you to burn wood in a more environmentally friendly way, reduce the maintenance required for your chimney and get more out of your wood. There are 3 stages in the wood-burning process:

Evaporation

When you light the cooker a lot of energy will be needed at first to boil away any moisture, which is left in the wood. Using energy to drive off excess water in firewood robs the cooker of energy needed for an efficient and clean burn. Also, much of the energy wasted in evaporating water is energy that could have heated the hot-plate and ovens. This is a waste of wood, money and effort. The presence of all that moisture tends to keep "putting out" the fire, and therefore making it burn very poorly, which tends to produce a lot of creosote and pollution.

Emissions

As the heat of the fire intensifies, waste-gases (smoke) are released from the wood. Unburned smoke is emitted into the air either as pollution, or condensed in the chimney causing creosote build-up. It takes time for the air in your chimney to heat up. When it is still cold you get an effect similar to the condensation of hot breath on a cold window or mirror. So when the by-products of combustion (smoke in the form of gases) exit the cooker, and flow up into the relatively cooler chimney, condensation occurs.

The resulting residue that sticks to the inner walls of the chimney is called creosote. Creosote is formed by unburned, flammable particulates present in the smoke. It is black or brown in appearance. It can be crusty and flaky, tar-like, drippy and sticky or shiny and hardened. Quite often, all forms will occur in one chimney system. If the wood you are using is water logged, or green, the fire will tend to smoulder and not warm the chimney sufficiently. Wet wood causes the whole system to be cool, and inefficient. In contrast: dry wood means a hot fire, which results in a hot flue. A hot flue means much less creosote clogging up your chimney. The cooker's firebox is designed to operate at very high temperatures to burn the gases and particles released from the wood, which means less air-pollution.

Charcoal

When most of the tar and gasses have burned the remaining substance is charcoal (ash in its finer form). A hot bed of charcoals and ash can enhance the combustion process when burning larger pieces of wood. Start with a small fire to develop a bed of glowing embers. As the charcoal bed develops and the cooker heats up, slowly add larger and larger pieces of wood. It takes time to build a good charcoal bed, but it is

well worth the effort. Only empty excess ash periodically and always leave a bed of ash on which to light the next fire.

OPERATING TIPS

By taking time to get to know your cooker, following our maintenance guidelines and using good quality fire-wood you should enjoy trouble free operation of your wood fired cooker. It is also worth bearing in mind these useful operating tips:

- Don't leave the cooker lit for long periods in slumbered down mode (as you would for overnight burning), open the air control and bank up the fire periodically to heat up the cooker and flue to prevent soot build up.

WHAT TYPE OF WOOD IS BEST?

The difference between 'hard' and 'soft' woods is the density of their cells or fibres.

As a general rule, the deciduous trees (those that lose their leaves in the autumn) are usually thought of as hardwoods and the evergreen trees (such as pines, firs and spruce) as the softwoods. But generalisations are of course always subject to many exceptions. Some evergreens may well be harder than some deciduous trees. Birch, for example, is not very hard at all. So we should understand that there is a whole range of densities amongst our tree species, including medium dense woods, which cannot be satisfactorily classed as hard or soft.

Firewood tends to be sold by volume rather than weight. Assuming that the wood is reasonably dry, the weight of a square foot of good hardwood may be double of that of a square foot of softwood. This means that the same volume of hardwood will provide you with more fuel to burn than an equal amount of softwood, simply because it contains more substance.

(N.B. The price of hardwood will normally not be double that of softwood, because it took the same amount of labour to prepare. So, if a trailer full of hardwood costs more than the same size trailer full of softwood, the more expensive option may well be the most economical.)

The other advantage of good hardwoods are that the cooker does not need to be fed as often and the charcoal-beds made by the glowing wood may burn more easily overnight.

However, the ideal situation would be to have a store of both hard and soft woods, because the softer woods also have distinct advantages. They light more easily than the slower burning hardwoods and if the softwoods are dry, they create a hotter, more intense fire. The draught created by the hotter fire moves the air up the chimney faster.

After reading the notes about the burning process, you will understand that means less pollution in the form of smoke and less creosote condensation in your chimney. The denser hardwoods tend to smoulder more easily when the fire is lit first, so their flue gas temperature will be much cooler.

Because softwoods like pine and spruce contain a lot of resins and pitch, a popular misconception is that they will fur up the chimney with creosote more easily than a hardwood like oak. This is not necessarily true at all. It is not the pitch that is the problem, Rather it's the water in the pitch. Once the water in the wood has evaporated, that pitch becomes high octane fuel! When dry, softwoods burn extremely hot!

There is also the matter of seasoning to be considered. When you buy wood, it will usually have been cut in the winter of the year you buy it. Hard woods tend to take longer than softwoods to fully dry out.

Softwoods cut in the previous winter should, with proper storage, be ready to burn the next autumn, where-as many hardwoods may take a bit longer than that. Oak, for example, is very slow to dry out and ideally left for two years. It is also possible to purchase pre seasoned wood.

Summarising we can say that it is always sensible to buy this year for the next years fuel supply and that it is very handy to have both soft and hardwoods available. You can use the softwoods to start a good fire and you will have additional control over the fire (in addition to the cookers controls) by adding slower burning wood to the faster burning ones if you want to leave the cooker without tending it for a while. Alternatively you can add some fast burning softwood logs to the slower hardwood logs to instantly revive a fire, which has been neglected.

THE IMPORTANCE OF A HEALY FLUE

The successful operation of your range cooker is entirely dependent on the adequate performance (pull) of the chimney or flue to which it is connected. The following maintenance guidelines will not have the desired impact unless the flue is also maintained and cleaned regularly. How often it needs cleaning will depend on the quality and moisture content of the wood you burn but an annual clean is recommended. A partially blocked or dirty flue can have disastrous implications for an otherwise perfectly installed cooker. Tar deposits will build up if the flue performance is poor and clogged with old soot.

FIGURE 11A:
HEALTHY FLUE: THE
FLUE DRAUGHT METER
SHOWS A READING
BETWEEN 12 AND 24
PASCALS OR 0.12MM
AND 2.5MM OR 0.05WG
AND 0.1WG WHICH IS
IDEAL FOR OPTIMUM
FIREBOX PERFORMANCE

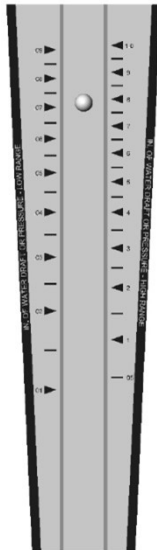
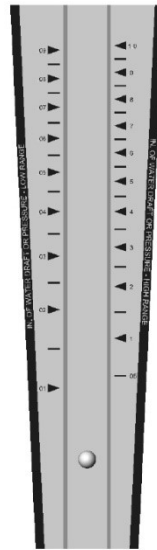

FIGURE 11B:
UNHEALTHY FLUE: THE
FLUE DRAUGHT METER
SHOWS A READING WELL
BELOW THE REQUIRED
OPERATING RANGE THAT
WILL RESULT IN POOR,
SMOKEY PERFORMANCE.



CLEANING THE FLUE WAYS - EVERY 3 MONTHS

Always carry out cleaning procedures when the cooker is out and has been allowed to cool sufficiently to avoid burns. With time and experience you will be able to gauge the intervals between flueway cleaning more accurately. It will vary depending on the quality of your firewood and performance of your flue.

Take time to get to know your cooker and inspect it at regular intervals for the first 6 months. We recommend that a flue brush of the type shown below (Fig 18B) is used to clean the flue ways. Its flexible wire handle is ideal for pushing the brush head round bends and into narrow spaces.

Hotplate & Primary Flueway

Remove the hotplate securing screws and use the hotplate lifting tools (Fig 21A) that came with your cooker to remove the hotplate and if required give the surfaces under the hotplate and above the firebox and top oven a light scrub with a wire brush and vacuum out any debris.

FIGURE 12A: HOTPLATE LIFTING TOOL



FIGURE 12B: FLUE BRUSH

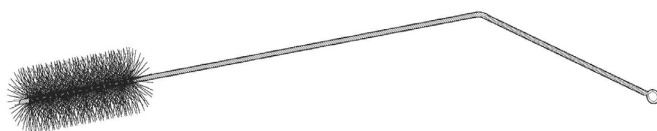
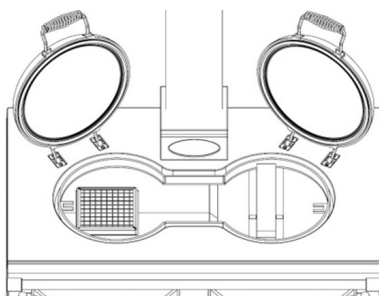
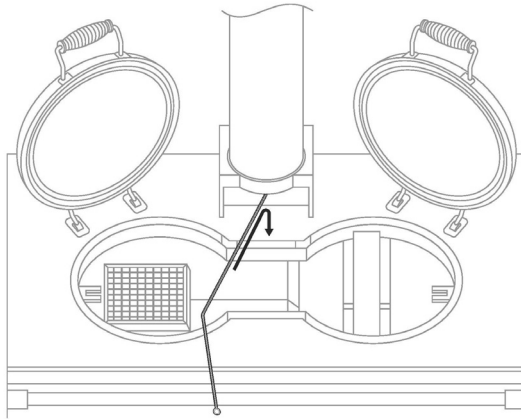

FIGURE 12C: REMOVE THE HOTPLATE, LIGHTLY SCRUB ALL SURFACES WITH A WIRE BRUSH AND VACUUM UP ANY DEBRIS.



Flue box and Flueway

FIGURE 13: ACCESS THE REAR FLUEWAY VIA THE FLUEBOX.



Remove the front of the flue connector box and insert the flue brush from left to right, angling the brush down at 45°. Once you find the flue way entrance push the brush down until it stops then gently but firmly pull back and forth 3 or 4 times then remove the brush. Dislodged soot will fall into the tray between the ovens.

Additionally there is a removable panel in the rear of top right hand oven.

To use this, open the right hand oven door and remove the oven shelf. Using the cooker tool, the panel can be lifted vertically by a few millimetres and then tilted out at the bottom and slid out. This will now give you access to the rear flueway, which can be brushed with the flue brush. The soot will fall into the tray between the ovens.

FIGURE 14: REMOVAL OF REAR PANEL TO ACCESS THE REAR FLUEWAY.

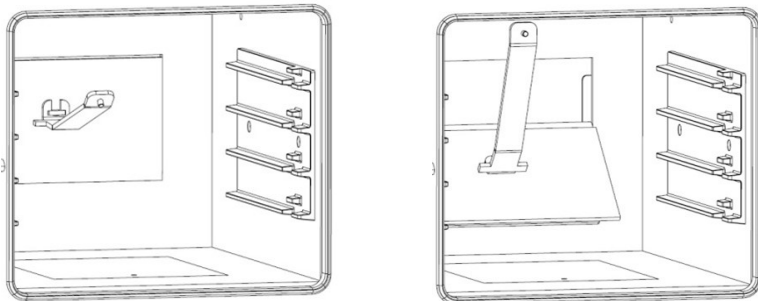

Right Side Flueway

FIGURE 15: ACCESS THE RIGHT SIDE FLUEWAY VIA THE TOP OF THE COOKER.

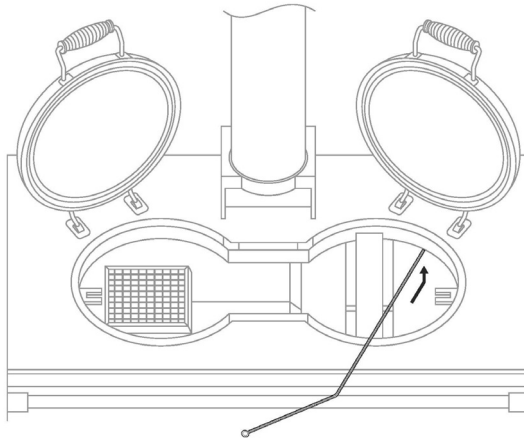

There are two methods to clean the right side flueway. The first is to insert the brush at a shallow angle as shown above. The brush will need to turn 90° into the flueway so steady pressure will be needed to help the brush head round the bend. Once in, work the brush up and down and front to back as the flue way runs along the entire depth of the ovens. Again, soot will fall into the trap between the ovens.

The second method is to open the top right oven door and remove the oven shelf. Then by gripping the right hand shelf runner, the runner can be lifted a few millimetres and the shelf runner can be tilted out at the bottom and removed from the oven. This will give you access to the right side flue way which you can then use the flue brush to clean the flueway. Again, soot will fall into the trap between the ovens. If the shelf runner is reluctant to lift, it can be tapped with a mallet.

FIGURE 16: REMOVAL OF SIDE PANEL TO ACCESS THE RIGHT SIDE FLUEWAY.

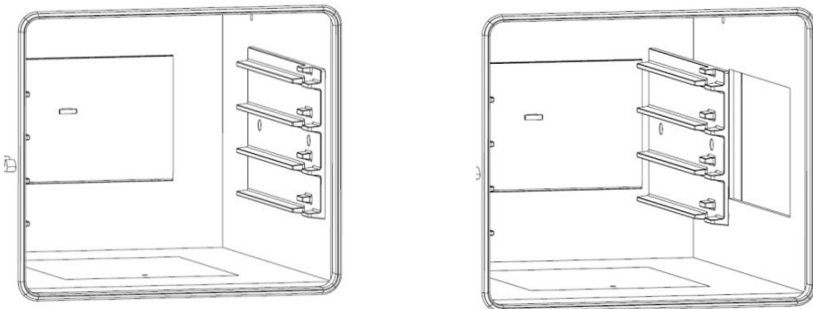

Cleaning the Flueway Between the Ovens

Remove the inspection cover in the base of the main oven and insert the flue rake, raking from side to side and making sure the rake reaches the back and the side of the flue boxes. Vacuum the soot.

FIGURE 17: REMOVAL OF BASE PLATE TO ACCESS THE FLUEWAY IN BETWEEN THE OVENS.

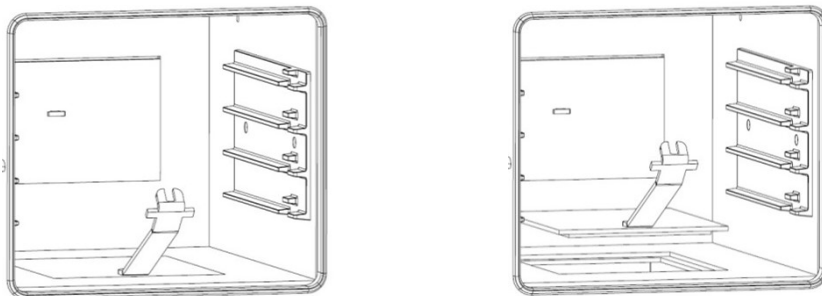
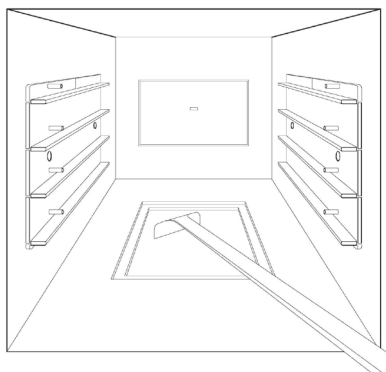

FIGURE 18: USE THE FLUE RAKE TO PULL ANY SOOT OR GRANUALS INTO THE OPEN SPACE TO BE VACUUMED.



CLEANING THE EXIT FLUE - EVERY 6 MONTHS

It is essential to maintain the integrity and cleanliness of the flue to ensure that your cooker continues to perform at its best. When your cooker was installed the main flue should have been equipped with an inspection hatch; either in the blanking plate above the cooker next to the flue pipe (Fig. 28) or in the flue pipe itself. These hatches are designed to allow periodic access to the flue for cleaning which should ideally be done by a chimney sweep. Chimneys and flues vary widely in terms of size, shape, length and construction, but the principles of the way they work are the same. Keeping them clean and clear is essential to maintain the optimum performance of any wood burning or multi-fuel appliance.

FIGURE 19: LOCATION OF MAIN FLUE INSPECTION HATCH.

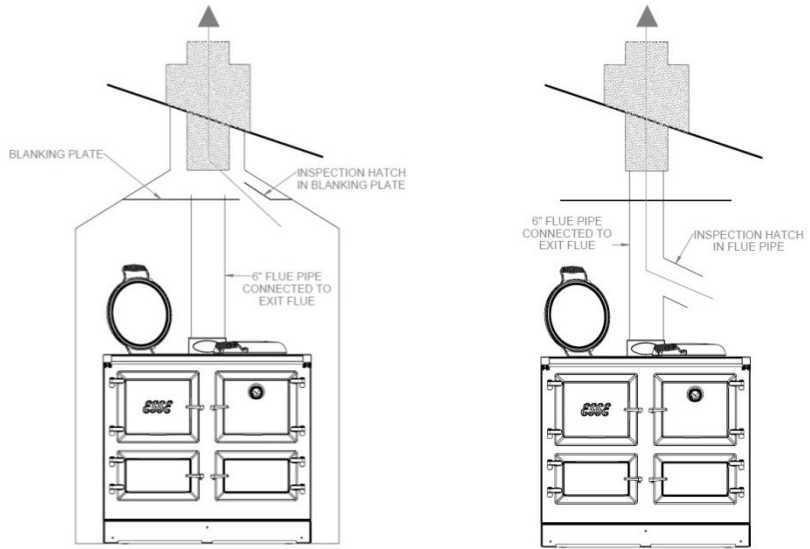

CARING FOR YOUR ESSE COOKER

Your ESSE cooker is easy to keep clean.

The cast iron hotplate helps to clean itself, by carbonising cooking spills and splashes. Just brush off the carbon dust. For stubborn stains, don't be afraid to use a wire brush on the cast iron hotplate and inside the ovens.

Splashes and spills should be wiped away as soon as possible, using a damp soft cloth.

If spills have become baked on use a soapy cloth, not too coarse, so as to avoid scratching. DO NOT use oven cleaners.

Likewise the inner door panels and inner bolster lids can be cleaned with a cream cleanser or for more stubborn marks, a soap filled pad. The linings will show marks and discolour with use, but with regular cleaning will maintain its look for longer. The bolster lids and handrail can be cleaned with a damp soapy cloth, followed by a wet cloth, finishing by polishing with a clean dry cloth.

Any spillage of milk or fruit juices on to the surfaces must be wiped up straight away, as the acidity may stain.

Some components such as the side panels are powder coated (painted) and nothing abrasive should be used on them. Use a soap filled pad instead.

If the cooker is finished in a matte painted finish, additional care must be taken not to use any chemicals or abrasive cleaners. Use a light brush or lint free cloth instead.

If the cooker is not going to be used for an extended period of time, we advise that the cooker be cleaned thoroughly, the ovens and hotplate can be wiped over with a light coating of cooking oil, the bolster lids left up and the doors left slightly ajar.

During the life of your cooker it may be necessary to adjust the door handles and change the door ropes. The door handles can be adjusted using the adjustment screw on the lift up latch part of the handle. Replacement door ropes can also be purchased from www.esse.com.

Replacing the Firebox Door Glass:

The firebox door glass can be changed easily if damaged or broken.

FIGURE 20: MAKE-UP OF THE INNER FIRE DOOR.

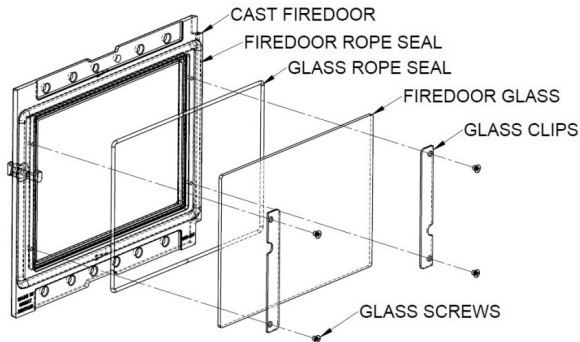

1. When the cooker is cool, open the firebox outer door and the firebox inner door.
2. Remove the 2 glass screws and clips (take care to support the glass to ensure it doesn't fall out and break, or of any sharp edges if the glass has broken).
3. The glass can now be removed. It may require a tap of the hand to get it off the seal.
4. If replacing the seal, the rope seal can now be removed and the rope groove cleaned.
5. A replacement rope seal (Part No: ROPE/CUT.WHT/3x1040mm) can now be fitted in place.
6. A new glass panel (Part Number: 990-007C) can now be fitted using the existing glass clips and screws.



WARNING: Do not use normal glass or other substitute materials in the inner firebox door.



WARNING: Do not clean the inner firebox door glass when hot.

REPLACEMENT PARTS

GUARANTEE

Conditions of Guarantee

Your ESSE is guaranteed against defects arising from faulty manufacture for 2 years when supplied by an ESSE Specialist.

Your details must be registered with us by completing registration on-line at www.esse.com. The warranty must be registered within 1 month of installation.

The appliance must be only used for normal domestic purposes and in accordance with our instructions, be correctly installed and serviced.

The guarantee does not cover:

- Installation
- Wear and tear
- Parts deemed to be replaceable or service parts that may be replaced during the normal usage of the appliance.
- Damage to the painted finish caused by impact, spillage, water ingress or condensate attack from flue or by using unsuitable fuels.

This guarantee is personal to the original purchaser and not transferable. Any cooker or defective part replaced shall become the Company's property

How to Proceed With a Complaint

If you have cause for dissatisfaction with your cooker, you should first contact your ESSE dealer, who will bring your concerns to our attention. We will assess the nature of the complaint and either send replacement parts for your dealer to fit, or arrange for an ESSE engineer to inspect the appliance and carry out any work that may be deemed necessary. If the fault is not actually due to faulty manufacture but some other cause i.e. misuse, failure to install correctly, or failure to service at regular intervals, a charge will be made to cover the cost of the visit and any new parts required.

Customer Care

In the event you should require spare parts, please order through your ESSE dealer or purchase from www.esse.com.

SOLID FUEL BURNING APPLIANCE CONSTRUCTION DETAILS

ESSE

Australia

Distributed in partnership with Pivot Stoves

234-238 Moorabool Street

Geelong, VIC 3220

Phone: (03) 5221 4485

Website and On-line Store: www.pivotstove.com.au