

firewall

FLUELESS CAT GAS FIRED HEATERS

Model: 50" Optica & 60" Fissure



INSTALLATION & SERVICING INSTRUCTIONS

(TO BE LEFT WITH THE CUSTOMER)



ESSE Engineering Limited, Long Ing, Barnoldswick, Lancashire BB18 6BN

Tel: 01282 813235 Fax: 01282 816876 Website: <http://www.esse.com>



ESSE Engineering Limited, Long Ing, Barnoldswick, Lancashire BB18 6BN

Tel: 01282 813235 Fax: 01282 816876

Email: enquiries@esse.com Website: <http://www.esse.com>



1. TECHNICAL INFORMATION

OPTICA			
GAS	NATURAL GAS (G20)	PROPANE (G31)	LPG BUTANE (G30)/PROPANE (G31)
CATEGORY	I ₂ H	I ₃ P	I ₃ B/P (30)
HEAT INPUT (GROSS) MAX	2.6kW	2.6kW	2.6kW
HEAT INPUT (GROSS) MIN	1.7kW	1.9kW	1.75kW
SUPPLY PRESSURE	20 mbar	37 mbar	30 mbar
BURNER PRESSURE HIGH	19.8 mbar ± 0.5 mbar	36.4 mbar ± 0.5 mbar	27.0 mbar ± 1.0 mbar
BURNER PRESSURE LOW	10.5 mbar ± 0.5 mbar	23.0 mbar ± 0.5 mbar	11.5 mbar ± 0.5 mbar
INJECTOR SIZE	3/160	7/75	7/75
GAS CONNECTION	8mm O.D TUBE	8mm O.D TUBE	8mm O.D TUBE
GAS CONSUMPTION (HIGH)	0.23m ³ /h	0.1m ³ /h	0.076m ³ /h
OXYPILOT	SEAGAS NG 441	SEAGAS LPG 451	SEAGAS LPG 451

FISSURE			
GAS	NATURAL GAS (G20)	PROPANE (G31)	LPG BUTANE (G30)/PROPANE (G31)
CATEGORY	I ₂ H	I ₃ P	I ₃ B/P (30)
HEAT INPUT (GROSS) MAX	3.5kW	3.5kW	3.5kW
HEAT INPUT (GROSS) MIN	2.3kW	2.3kW	2.3kW
SUPPLY PRESSURE	20 mbar	37 mbar	30 mbar
BURNER PRESSURE HIGH	19.5 mbar ± 0.5 mbar	36.8 mbar ± 0.5 mbar	29 mbar ± 1.0 mbar
BURNER PRESSURE LOW	9.2 mbar ± 0.5 mbar	18.4 mbar ± 0.5 mbar	13.1 mbar ± 0.5 mbar
INJECTOR SIZE	7/220	7/100	7/100
GAS CONNECTION	8mm O.D TUBE	8mm O.D TUBE	8mm O.D TUBE
GAS CONSUMPTION (HIGH)	0.31m ³ /h	0.13m ³ /h	0.078m ³ /h
OXYPILOT	SEAGAS NG 441	SEAGAS LPG 451	SEAGAS LPG 451

2. FIREWALL OPTICA DIMENSIONS

Fig.1. 50" Optica / 60" Fissure dimensions

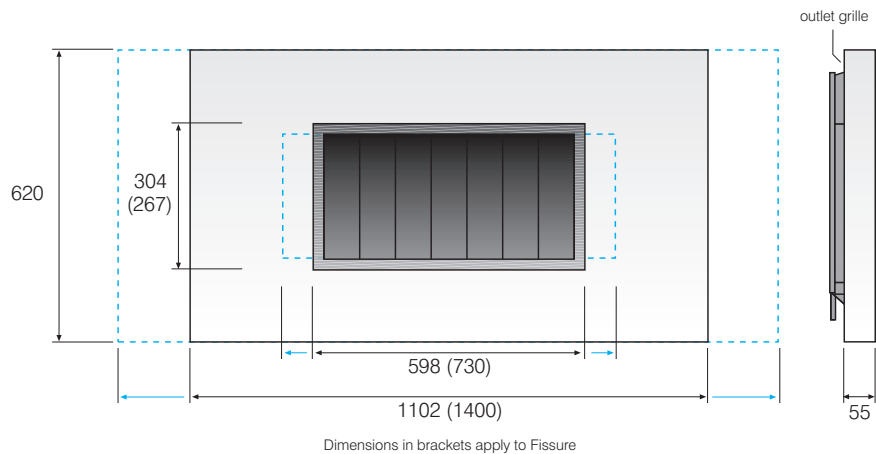

ALL MEASUREMENTS IN MM. SIZES ARE APPROXIMATE ONLY. VARIATIONS MAY OCCUR IN MANUFACTURE. DIMENSIONS SHOWN ARE FOR OPTICA WITH FISSURE DIMENSIONS IN BRACKETS.

3. MOUNTING DIMENSIONS

Fig.1a. 50" Optica Firewall

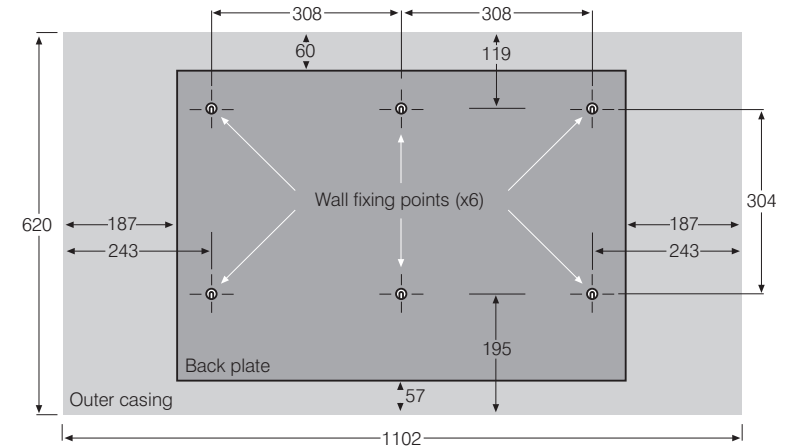
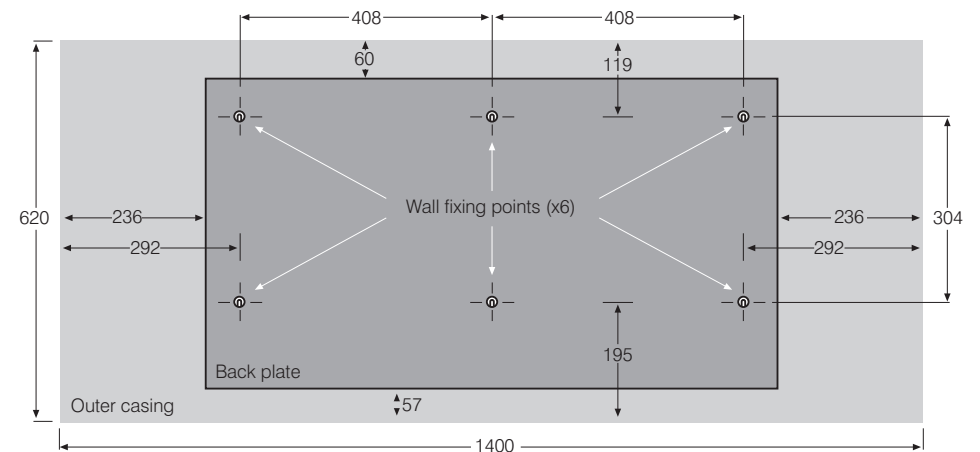

Fig.1b. 60" Fissure Firewall



4. IMPORTANT NOTES

This is a High Efficiency, Flueless Catalytic, Live Flame Effect heater. It provides radiant and convected warmth both efficiently and safely utilising the latest type catalytic convector burner technology. It is recommended that it is only used as a secondary heat source.

Before installation, ensure that the local distribution conditions identification of the type of gas, gas pressure and the adjustment of the heater are compatible. Refer to the Data plate situated on the underside of bottom tray (see Fig.2).

If the heater is to be operated on Propane, the M8 Aeration screw (with 4.5 diameter hole) should be fitted. If the heater is to be operated on Butane, or Butane/Propane mix or Natural Gas this aeration screw **MUST NOT BE FITTED** (Fig 3A).

The heater incorporates either a manually controlled gas valve, which can be adjusted by the control knob on the front of the gas valve, located on the lower right hand side of the heater behind the front panel (see Fig.2) or a remote controlled gas valve controlled by a handset.

This heater incorporates a combustion monitoring system (ODS). It must not be adjusted or put out of operation. If replaced then manufacturers original parts must be used.

The heater is designed to fit various types of situations as listed in the Installation Requirements.

This heater must be installed in accordance with these instructions and with the rules in force and only used in a sufficiently ventilated space. A minimum of 100cm² purpose provided ventilation is required for this appliance. An openable window or equivalent is also required. This appliance is factory set for operation on the gas type, and at the pressure stated on the appliance data plate.

The room size should be a minimum of 30m³ (1059ft³) for the Widescreen 41" model and a minimum 40m³ (1412ft³) for the Widescreen 48" model. This volume may include adjacent spaces but these spaces must not be separated by a door.

The heater must not be installed in a bedroom, bathroom or any sleeping area. Additionally for LPG, the heater must not be used in cellars or basements. The heater does not require a flue system of any type as the catalytic converter cleans the flue products to provide a complete combustion system.

The heater must be installed by a competent person in accordance with Gas Safety (Installation and Use) Regulations 1998 or rules in force. In particular, as the gas supply pipe may well be concealed within a wall, attention is drawn to regulation 19 'Enclosed Pipes'. It is strongly recommended that a CORGI registered engineer is used for this purpose, as they are the only persons approved by the HSE under the above regulations.

On initial light up of a new heater, the 'newness' will burn off within the first few hours of operation. During this period some smoke may be emitted from the outlet grille, this should be no cause for concern. Accordingly, the room should be well ventilated with all windows and doors open during this period.

All surfaces except the controls are considered to be working surfaces.

Fig.2. Fitting the outer casing

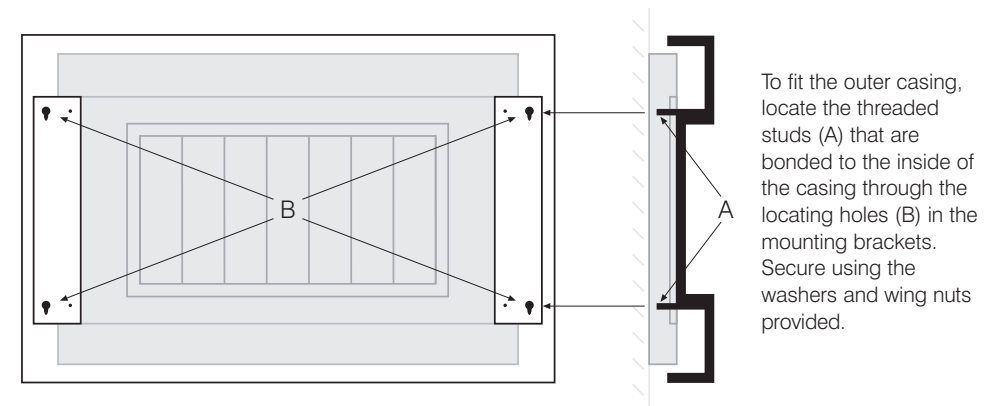

5. INSTALLATION

This heater is designed to be wall mounted. The wall should be reasonably flat and of sufficient size to accommodate the heater (see Fig.1). If the appliance is to be sited near a disused natural draught flue it is recommended that the old flue should be partially sealed off to prevent draughts, however some ventilation will be required to prevent condensation.

ROOM SIZING

The room size should be a minimum of 30m³ (e.g. 12' x 12' x 7'6") for the Widescreen 41" model and a minimum of 40m³ (e.g. 14' x 14' x 7'6") for the Widescreen 48" to allow adequate circulation of air and ensure the correct operation of the heater. This volume may include adjacent spaces but these spaces must not be separated by a door.

SITE REQUIREMENTS

This heater may be installed in any room in a home; however there are exceptions, and the heater may not be used in bedrooms, bathrooms or shower rooms. Additionally for LPG, the heater must not be used in cellars or basements.

Installations in living rooms and conservatories are popular, however other rooms such as kitchens, dining rooms and hallways are permitted, providing a suitable gas supply is available, and room sizing and ventilation requirements are strictly adhered to.

The heater is designed to be versatile, and as such will operate correctly when exposed to normal gentle draughts experienced within the home. It is not recommended, however that the heater be installed in areas where it is likely to be exposed to persistent strong draughts, that may be generated by outside doors, windows or air vents. It is recommended that the heater should not be installed within 1 metre of any air vent.

CLEARANCES TO NON-COMBUSTIBLES

Non-combustible surfaces are defined as brick, metal, marble, concrete etc, and also a number of man-made materials impervious to flame. If in doubt refer to the material manufacturer for further information before proceeding with installation.

It is recommended that there is at least 400mm (16") clearance above the outlet grille. Minimum clearance from the bottom of the outer frame to the floor must be 90mm (3.5"). Clearance to the sides of the heater is 50mm (2"), however, clear and easy access to the controls located on the lower right hand side of the heater behind the front panel on the right hand side must be allowed for, and we would therefore recommend that at least 100mm (4") be allowed. Clearance to the front of the heater is 500mm (2ft). Care must be taken that no brickwork or other incombustible material protrudes into the area immediately around the base of the heater or area underneath the heater in a way that is likely to affect natural airflow into or around the heater.

CLEARANCES TO COMBUSTIBLE MATERIALS

Combustible materials are defined as wood, fabrics, or other materials likely to combust if exposed to flame. Generally, any material, which is likely to discolour, melt or misshape when exposed to moderate heat, should be considered as a combustible material of surface. Any fire surround or shelf to be used in conjunction with this heater should be rated at a minimum of 100°C otherwise discolouration of smells may occur. If in doubt refer to the surround / shelf manufacturer.

Minimum clearance from the bottom of the outer frame to the floor must be 90mm (3.5").

The heater may be mounted directly onto a combustible wall.

Clearance to the sides of the heater is 100mm (4") but curtains, drapes and other fabrics are not permitted within a distance of 500mm (20") of the heater sides. No such materials are permitted directly above the heater regardless of distance. Clearance to the front of the heater is 1000mm (39in).

The minimum clearance to the ceiling above the top of the outlet grille must be at least 1067mm (42").

A combustible shelf may be fixed to the wall above the heater, providing that it complies with the dimensions given below:

Warning! Under no circumstances must any electrical device (e.g Plasma T.V.) be wall mounted above a firewall.

Maximum depth of shelf	Minimum distance from top of outlet grille to underside of shelf
75mm (3in)	305mm (12in)
150mm (6in)	457mm (18in)
457mm (18in)	1067mm (42in)

The shelf depth may be increased up to a maximum of 457mm (18") but the height must also be increased accordingly. An increase in height of 25mm is required for every 12.5mm of additional shelf depth. For shelves that are too low, protective devices can be used such as metal heat deflectors, but it must be assured that the shelf does

not reach an unacceptable temperature before relying on such a solution.

As with all heating appliances, any decorations, soft furnishings, and all coverings (i.e. flock, blown vinyl and embossed paper) positioned too close to the heater may discolour or scorch.

VENTILATION

A minimum of 100cm² purpose provided ventilation is required for this heater. An openable window or equivalent is also required. The requirements of any other flued appliance operating in the same room or space must be taken into consideration when assessing ventilation.

Any ventilation fitted must comply with BS 5871 and BS 5440 part 2. Ventilation fitted under, or within

immediate vicinity of the heater must not be used as it may adversely effect performance of the ODS system. The heater **MUST NOT** be installed in a bedroom, bathroom or any sleeping area. Additionally for LPG the heater must not be used in cellars or basements.

For Republic of Ireland, see relevant rules in force and I.S.813.

SECURING THE HEATER TO THE WALL (Fig. 4)

Select a suitable site for the heater. Remove the wall plate from the heater body (4 x M5 nuts) (Fig.4). Mark the position of the four securing holes using the wall plate as a template, ensuring the wall plate is level and that the letter 'T' is at the top.

Drill and plug the wall with suitable wall plugs. Secure the wall plate to the wall using suitable screws ensuring the wall plate is level. Secure the heater body to the wall plate using the M5 nuts and washers provided.

GAS CONNECTION

The gas inlet connection is located on the gas valve underneath the heater at the right hand side (Fig.4). The gas supply may connect to the heater over the wall or by concealed connection below the heater. Concealed pipes should not be routed through walls without being protected by sleeving or conduit. No more than 2.5m of 8mm dia pipe must be used to avoid unnecessary pressure drops.

An isolation tap should be provided on the gas inlet to the heater.

If a concealed gas connection is to be made, the supply pipe should always be sleeved through walls and floors using the shortest possible route.

When making the gas connection ensure that the front panel will not foul the pipe or isolation tap. If the heater is to be operated on propane, the M8 aeration screw should be fitted. If the heater is to be operated on Butane or Butane/Propane mix or Natural gas this aeration screw **MUST NOT BE FITTED** (FIG 3B)

Fig.3A - Manual version

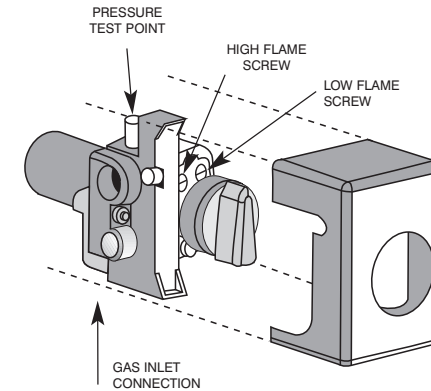

Fig.3C - Aeration screw

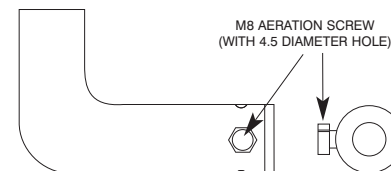
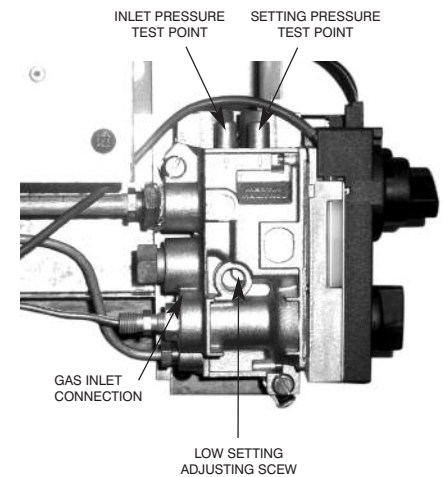

Fig.3B - Remote control version



6. FITTING THE VERMICULITE GRANULES

If fitted, remove the screws securing the mounting brackets for the black glass front (4 screws either side of glass frame). Remove the glass frame securing nuts and remove the glass frame complete (Fig.4). Pour the vermiculite granules into the burner. Fill the burner completely to the top as shown below.

Do not overfill the vermiculite over the top of the burner in the area of the pilot flame.

Fig.4 - Fitting the vermiculite granules

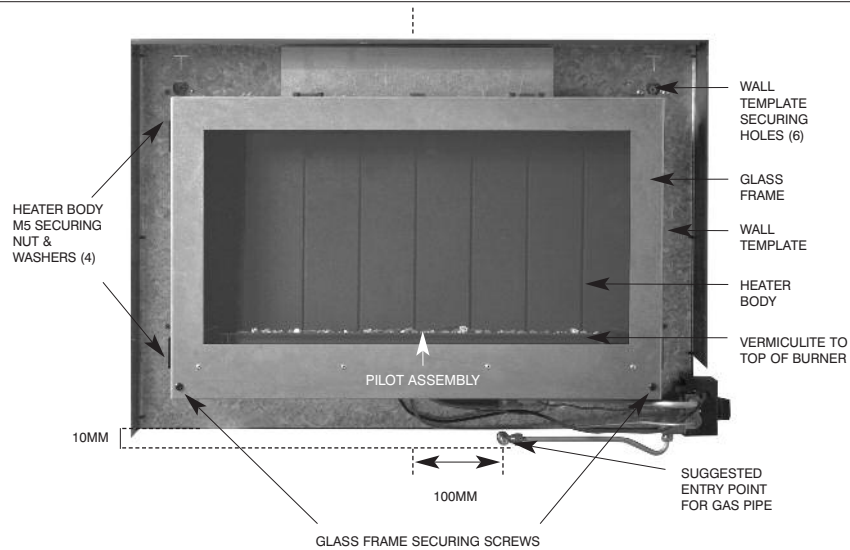

Note: Replace the glass frame and mounting brackets for black glass front if fitted and fit the data plate panel (steel version only), front panel and outer frame. Fit the steel front panel & secure using the 2 screws provided (Fig.2) OR fit the black glass front (Fig.2). Under no circumstances should the heater be operated with the glass frame removed or the glass damaged or without the vermiculite granules.

7. COMMISSIONING THE HEATER

(A) MANUAL VERSION - LIGHTING

The heater is fitted with a pilot light, which is also an oxygen depletion sensor (O.D.S), piezo spark, and flame sensing device. The control is located behind the front panel on the right hand side of the heater (Fig 2). The pilot light is located at the right hand end of the burner.

Should the heater be extinguished for any reason wait 3 minutes before re-ignition is attempted. Pull the control valve plastic cover forward and remove (Fig.3A). Slacken the pressure test point sealing screw and connect a suitable pressure gauge to the pressure test point (Fig.3A).

(a) Lighting the Pilot (Fig.5)



Depress control knob fully. Whilst depressed turn knob slowly anti-clockwise to 'PILOT'  setting.

A click will be heard and the spark should light the pilot, repeat until pilot is visibly lit. The operation of the spark can be viewed on the pilot assembly at the right hand end of the burner.

Keep knob depressed at this point for 10 - 15 seconds and release the knob. Preferably the pilot should be left to stabilise for approximately 5 minutes before igniting the burner.

(b) High Setting (Fig.5)

If the pilot is not already lit, light the pilot as described above.

With control knob at 'PILOT'  setting, depress and turn anti-clockwise to 'HIGH'  setting and release the knob. After a few seconds the burner will light on high setting.

Check that the high burner pressure is in accordance with that given in the TECHNICAL INFORMATION section. The pressure is factory set and should not require adjustment but if necessary adjust the HIGH FLAME SCREW (Fig.3A).

(c) Low Setting (Fig.5)

If the heater is not already lit on 'HIGH'  setting, ignite the heater to 'HIGH'  setting as described above.

Turn the control knob until 'LOW'  setting is reached. Check that the LOW burner pressure is in accordance with that given in the TECHNICAL INFORMATION section. The pressure is factory set and should not require adjustment but if necessary adjust the LOW FLAME SCREW (Fig.3A).

(d) Turning the Heater OFF (Fig.5)

From any heat setting, depress the control knob fully and turn clockwise to 'PILOT'  position. Disconnect the pressure gauge, tighten the pressure test point sealing screw and test for gas soundness. Replace the control valve plastic cover.

(e) Turning the Pilot OFF (Fig.5)

From any heat setting or the 'PILOT'  position, depress the control knob fully and turn clockwise to 'OFF' position.

(B) REMOTE CONTROL VERSION - LIGHTING

This heater has a pilot that must be lit manually. When lighting the pilot, follow these instructions exactly. Should the heater be extinguished for any reason wait 3 minutes before re-ignition is attempted.

Slacken the right hand pressure test sealing screw on the gas valve (Fig. 3B) and connect a suitable pressure gauge.

Note: Knob A cannot be turned from 'PILOT' to 'OFF' unless knob is pushed in slightly. Do not force.

(a) Lighting the Pilot

Turn knob A (Fig 1) counter clockwise towards the ignition position (IGN) until reaching stop, press down and hold for five seconds (only pilot gas flows). Continue pressing down knob A while turning further counter clockwise to activate piezo, continue to hold down for ten seconds after pilot burner has been lit. If pilot does not light, steps 1 and 2 can be repeated immediately. Upon lighting, release knob and turn further counter clockwise to ON position. Pilot gas flows and main gas flows in accordance to the temperature setting knob B.

(b) High Setting (Fig.6)

If the pilot is not already lit, light the pilot as described in (a). Turn knob B anti-clockwise until the high setting is reached. Check the setting pressure is in accordance with that given in the Technical Information setting. Adjust if necessary.

(c) Low Setting - (Fig.3B)

Turn knob B clockwise to low setting (just before flame is extinguished). Check that the setting pressure is in accordance with that given in the Technical Information section. Adjust if necessary.

Fig. 5 - Control knob

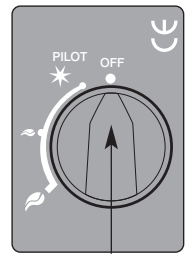

CONTROL KNOB

Fig. 6 - Remote control version - control knobs

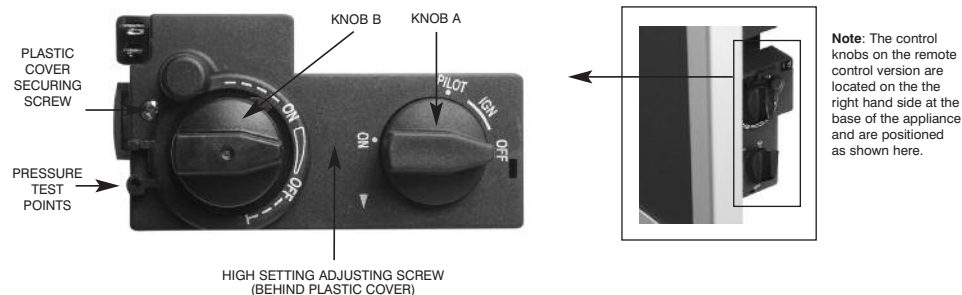

8. HANDSET OPERATION

Fig. 7 - Remote Transmitter G30-ZRHSO



Note: Mains electrical power is not required as this system runs on batteries only (alkaline recommended). Battery information: Handset – 1 x 9V block, Receiver – 4 x 1.5V AA.

Note: It is recommended to turn the combination control either to the off or pilot position if the appliance is left unattended for long periods (e.g. away on holiday), so that it cannot receive commands from the remote transmitter. Exercise caution when leaving the appliance unattended, in exceptional cases sound waves from sources other than the transmitter can cause flame height adjustment. For the handset to function correctly, the transmitter must remain within range of the receiver. The transmitter should not be used in very close proximity to the receiver (less than 1m/3ft) as this could, in very rare cases, produce an electronic switching error. This error could block the motor when the knob reaches the end points of its turning radius. The knob must then be turned manually to free the blockage.

FLAME HEIGHT ADJUSTMENT

- Simultaneously press both the (▲) button and the small button (A) to turn on the main burner or increase the flame height.
- For incremental increases in flame height, the small button must be continuously depressed while intermittently depressing the (▲) button.
- To decrease the flame height or shut off the main burner, simply depress only the (▼) button.

9. CUSTOMER BRIEFING

- Advise the customer how to use the heater.
- Advise the customer that the pilot light should be left on even if the main burner is switched off.
- Point out that the operating procedure is in the User Instructions.
- Explain to the customer that the heater has a flame sensing and oxygen depletion monitoring system.

- Point out the explanation of this system in the User Instructions.
- Advise that if the monitoring system repeatedly shuts off the heater, it should be switched off and a specialist consulted.
- Advise that if the heater goes out for any reason, wait at least 3 minutes before re-lighting.
- Advise the customer that due to newness of materials the heater may give off a smell for a period of time after commissioning and that this is quite normal and any odours should disappear after a few hours operation.
- Advise the customer that the heater should not be used if the glass becomes damaged or without vermiculite granules.
- Stress that no coals or logs must be added to the heater and that any replacement parts must only be authorised ESSE spares.
- Recommend that the heater is regularly serviced at least once a year by a qualified person.

10. SERVICING INSTRUCTIONS

The heater is fitted with a pilot light and flame-sensing device, which is also an oxygen depletion sensor (O.D.S). This is not adjustable and must not be put out of action. If any parts of this system requires replacement only original manufacturers parts must be used.

The following servicing procedure should be carried out regularly and only by a qualified person.

- Ensure that the heater is turned off and is cold.
- Remove the front panel, glass frame securing screws and the glass frame (Fig.2)
- Carefully remove any deposits of dirt, lint etc, from the vermiculite burner bed, aeration holes and pilot assembly with a soft brush. Do not use a vacuum cleaner near the vermiculite burner bed.
- Clean the pilot aeration 'hole'.
- Inspect the catalyst for sign of damage and dirt. The expected life of the catalyst is in excess of 11,000 hours (10 years of normal use). After this time the catalyst should be replaced. If there are any deposits of dirt or soot on the catalyst clean with a soft brush and a vacuum cleaner.
- Due to high temperature reached within the heater, surface cracks may appear on the backboard behind the flames. This is quite normal and will not affect the safe operation of the heater. Replace the glass frame.
- Check the high and low burner setting pressures as described in (5) **COMMISSIONING THE HEATER**
- Check the safe operation of the heater.

If a combustion analyser is available check the combustion performance of the heater as follows:

Light the heater on HIGH and after 15 minutes check the combustion performance is in accordance with Fig. 8 above the catalyser.

If the CO figures are more than given in Fig. 8 this suggests that the catalyser is due for changing or the aeration holes on the burner require cleaning or new vermiculite granules are required. Turn off the heater and investigate and correct.

Check that the purpose provided air vent is non-obstructed.

Fig. 8

	Above Catalyser
Co ppm	Less than 10
Co2 %	Approx. 3.0 - 5.0