

ESSE

G200L, G200 DOUBLE DOOR L
G225L

GAS FIRED MANUAL & REMOTE CONTROL STOVE

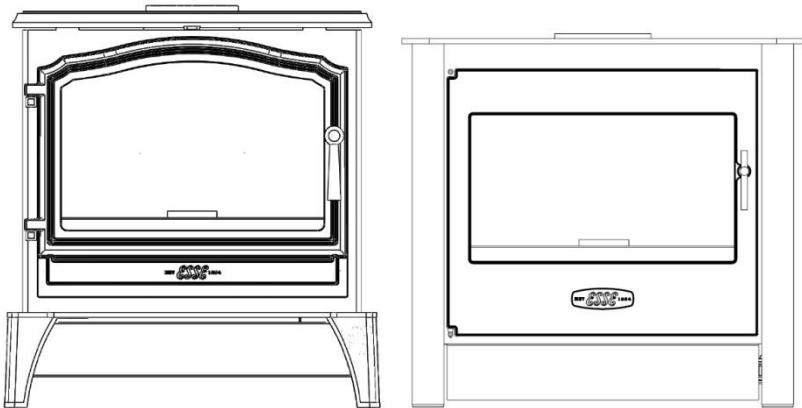

INSTALLATION, USER & SERVICING INSTRUCTIONS
(TO BE LEFT WITH THE CUSTOMER)
UK & IRELAND

G200L/G200DDL/G225L

*For use in UK & Ireland on Natural gas at a supply pressure of 20mbar or
Butane/propane at a supply pressure of 28mbar/37mbar*



GB

IE

INSTALLATION INSTRUCTIONS

CONTENTS

Important Notes	Page 2	Commissioning the Stove	Page 9
Technical Information	Page 3	Check for Spillage	Page 9
Dimensions and Clearances	Page 4	Customer Briefing	Page 10
Installation	Page 6		

IMPORTANT NOTES

- This stove is a fuel effect radiant convector. Before installation, ensure that the local distribution condition (identification of the type of gas and pressure) and the adjustment of the appliance are compatible. The data label is located at the rear of the stove. The installation must be in accordance with these Instructions and National Regulations and must be carried out by a qualified installer.
- Any flue damper plate or flue restrictor must be removed or fixed permanently in the fully open position, or shall only be fitted in accordance with National Regulations.
- If the chimney has previously been used to burn solid fuel, the chimney should be swept before the stove is installed.
- Before the stove is installed a flue test in accordance with National Regulations should be carried out. The gas connection must be in accordance with National Regulations.
- The stove is fitted with a spillage monitoring system consisting of a thermal switch connected to a thermocouple interrupter. This system is not adjustable, and must not be put out of action. If any parts of the spillage monitoring system require replacement only original manufacturers' parts must be used.
- All surfaces except the control knob and battery housing are considered to be working surfaces.
- The stove should not be used for any other purpose than as a room heater and a decorative stove.

TECHNICAL INFORMATION

Natural Gas Settings

G200L/G200DDL/G225L			
GAS			
GATEGORY	I _{2H}	I _{2E}	I _{2E+}
HEAT INPUT (NETT) HIGH/LOW	6.08kW/3.14kW	6.08kW/3.14kW	6.08kW/3.14kW
SUPPLY PRESSURE	20 mbar	20 mbar	20/25 mbar
INJECTOR SIZE	82/440	82/440	82/440
GAS CONNECTION	8mm O.D. Tube	8mm O.D. Tube	8mm O.D. Tube
GAS CONSUMPTION	0.65m ³ /h	0.65m ³ /h	0.65m ³ /h
NOX CLASS	5	5	5
EFFICIENCY CLASS	2	2	2
COUNTRIES OF DESTINATION	AT, CH, CZ, ES, FI, GB, IE, DK, EE, GR, LT, IT, PT, SE, LV, NO, SI,SK	DE, LU	BE, FR
OXYPILOT	Seagas P 456	Seagas P 456	Seagas P 456

LPG Settings

G200L/G200DDL/G225L			
GAS			
GATEGORY	I ₃₊	I _{3P}	I _{3B/P} (30)
HEAT INPUT (NETT) HIGH/LOW	6.28kW/3.14kW	6.28kW/3.14kW	6.28kW/3.14kW
SUPPLY PRESSURE	28/37 mbar	37 mbar	30 mbar
INJECTOR SIZE	92/200	92/200	92/200
GAS CONNECTION	8mm O.D. Tube	8mm O.D. Tube	8mm O.D. Tube
GAS CONSUMPTION	0.19m ³ /h	0.19m ³ /h	0.19m ³ /h
NOX CLASS	5	5	5
EFFICIENCY CLASS	2	2	2
COUNTRIES OF DESTINATION	BE, CH, ES, FR,GB, GR, CZ, IE, IT, PT, LT, SK	BE, CH, CZ, ES, FR, GB, GR, IE, IT, PT, SI, SK	CZ, FI, IT, SE, GR, NO, DK, EE, LT, SI
OXYPILOT	Seagas P 457	Seagas P 457	Seagas P 457

DIMENSIONS AND CLEARANCES

Fig 1a – G225L Dimensions

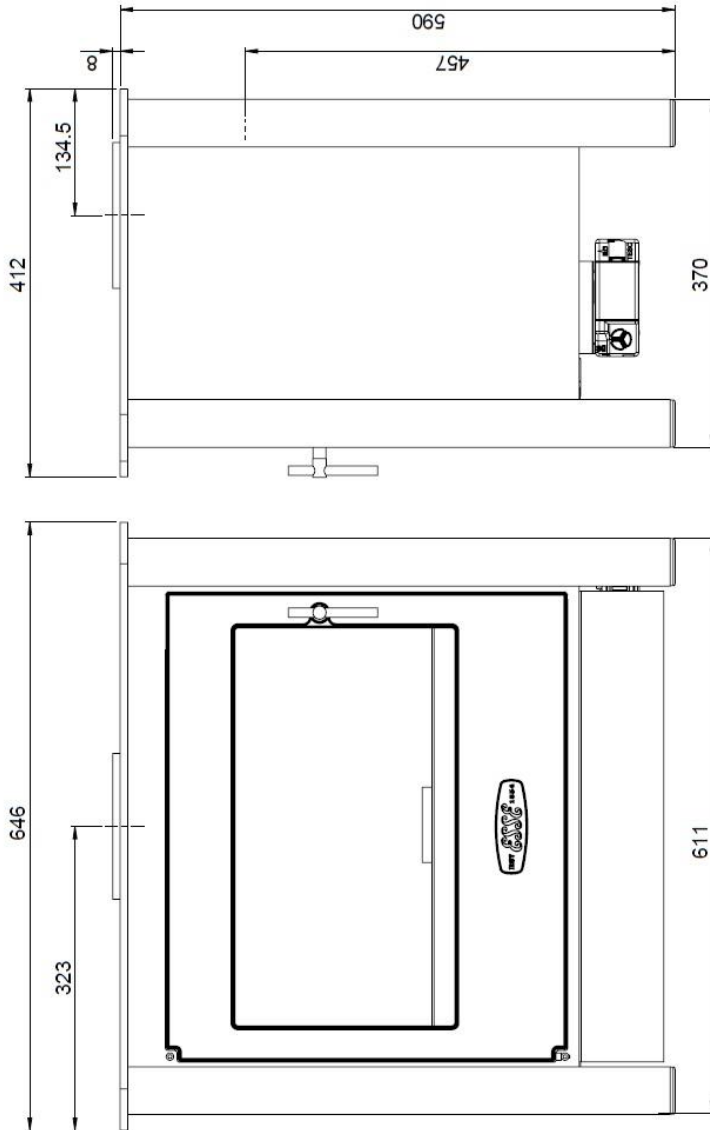
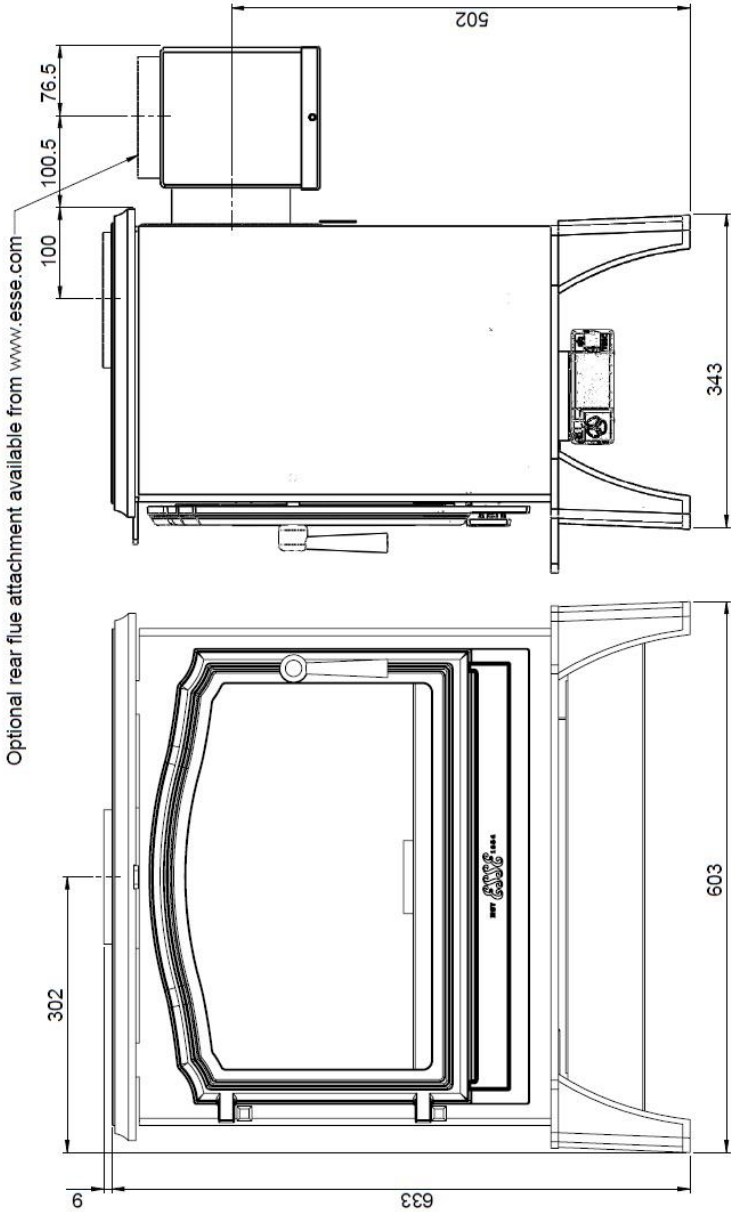

Fig 1b – G200L Dimensions



INSTALLATION

Install the stove in accordance with the requirements given below. If a concealed gas connection is to be made prepare the pipe work prior to installing the stove.

Positioning the Stove

Clearances from non-combustible material in the fireplace opening must be at least 50mm on the left side, 150mm on the right hand side and 50mm at the back. These distances must be extended to a minimum clearance of 400mm from any combustible material.

Hearth

The stove must stand on a fireproof hearth made of non-combustible material of a minimum thickness 12mm and be of sufficient size to accommodate the stove (see Fig.1a/b).

Fire Surround & Shelves

It is recommended that a fire surround should not be closer than 400mm from the stove, if manufactured from a combustible material.

A combustible shelf may be fitted provided that it is not more than 150mm deep and there is at least 400mm clearance from the top of the stove.

Log Arrangement

The logs should only be arranged as shown in the layout given in the Installation Instructions by a qualified person.

The stove must only be fitted with the ceramics supplied. **DO NOT** use any extra logs or coals.

Flue Connection

- The flue should be a minimum of 3m high and at least 125mm diameter or equivalent area.
- Horizontal or negative gradients in the flue pipe should be avoided.
- It is recommended that a minimum height of 610mm from the stove should be established before any significant change in the direction of the flue.
- An optional rear flue attachment is available as an accessory from www.esse.com (see Fig.1b).

Ventilation

Ventilation should be in accordance with National Regulations. In the United Kingdom, purpose provided ventilation is not normally required, except in new build houses.

For Republic of Ireland refer to I.S813 issued by the National Standards Authority of Ireland.

Gas Connection

- The gas supply connection is at the right hand side of the stove on the gas valve.
- A nut and olive (strapped to the valve body), tail pipe and a pressure test elbow are supplied with the stove for easy connection.
- The gas supply should incorporate a service tap, be purged and any loose matter removed.
- Connect the gas supply pipe and check for gas soundness.

TTB (Thermocouple interrupter)

Fig. 2 Shows the TTB connection on the back of the gas valve.

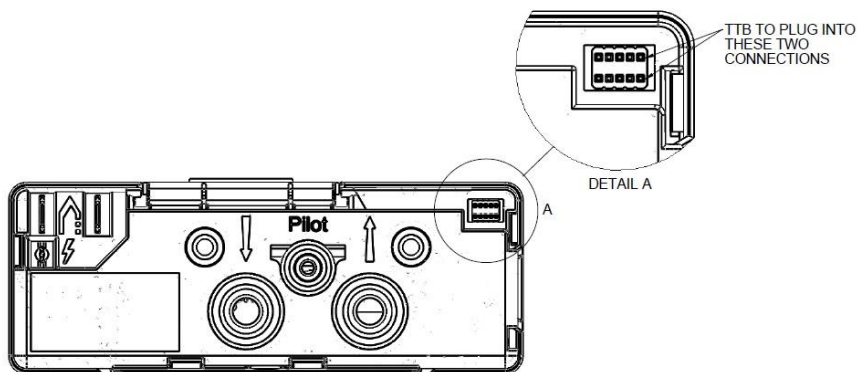

Positioning the Logs

1. Slacken the screw securing the door handle and open the stove door.
2. Position the back board into the burner tray ensuring that is correctly seated behind Tab A and that the flame strip is not obstructed (Fig 3).
3. Locate LOG1DMR and LOG2DMR into position on the back board as shown (Fig 4).
4. Locate LOG3DMR into position as shown (Fig 5)
5. Locate LOG4DMR into position as shown (Fig 5)
6. Close the stove door.
7. Tighten the door locking screw.

Fig.3



Tab A

Fig.4



LOG2DMR

LOG1DMR

Fig.5



LOG4DMR

LOG3DMR



WARNING

Under no circumstances should the stove be operated with the door open, without the door attached or the glass in the door damaged, broken or missing

COMMISSIONING THE STOVE

Once the fire is in place, connected, flued correctly, and the logs are in place, you can proceed with lighting the stove and ensuring the all the features are working correctly.

- The Fire control unit is located behind the right-hand foot of the stove.
- The pilot light is located at the front toward the left hand side of the burner.
- Should the stove be extinguished for any reason wait 3 minutes before attempting re-ignition.
- Connect a suitable pressure gauge to the pressure test point to check the correct inlet pressures.
- Fit AA batteries to the Fire control unit. The control requires 3 AA size alkaline batteries to be inserted under the battery compartment cover. The orientation of these is shown moulded into the battery compartment.
- After fitting the batteries and replacing the cover the fire can now be operated.
- Slide the Master switch to the right to the ON position (I symbol).
- To start the fire, press the ON/OFF button and hold for 1 second then release. The burner will within around 1 to **10** seconds ignite and adjust to the maximum power setting. This can take longer on the first lighting as it has to clear out any air locks, also if it is an LPG burner and has been stood unused for time, the gas could have settled in the pipework and again this could take longer.
- The power of the burner can be adjusted up and down by pressing the + and - buttons.
- To stop the fire, simply press the power button again and the burner will stop.

Once the fire has been successfully lit and extinguished, you can then put batteries in the Remote control and check that this is functioning correctly (See user instructions for how to set the time and date on the handset).

CHECK FOR SPILLAGE

Close all doors and windows in the room containing the appliance. Light the stove and set the control unit to 'HIGH', leave the appliance for 5 minutes.

Apply a smoke match along the bottom edge of the draught diverter. The installation is satisfactory if the smoke is drawn into the stove. If in doubt wait a further 10 minutes and then repeat the test.

If there is a nearby room with an extractor fan the spillage test should be repeated with the fan running and all connecting doors between the stove and the fan left open.

If in doubt disconnect the appliance and seek expert advice.

CUSTOMER BRIEFING

- Hand these Instructions to the customer.
- Advise the customer how to use the stove.
- Explain to the customer that the stove has a flame failure and spillage monitoring system.
- Point out the explanation of this system is in the Operating the Stove section of the instructions.
- Advise that if the monitoring system repeatedly shuts off the stove, it should be switched off and a specialist consulted.
- Advise that if the fire goes out for any reason, wait at least three minutes before re-lighting.
- Advise the customer that due to the newness of materials the stove may give off a slight smell for a period of time after commissioning. This is quite normal and any odours should disperse after a few hours operation.
- Stress that no extra logs must be added over and above those supplied with the appliance and that any replacements must only be authorized Esse spares.
- Recommend that the stove is regularly serviced and the flue system checked by qualified persons.

Installer's Name	Installer's Telephone Number
Installer's Company	Appliance Serial Number

USER INSTRUCTIONS

CONTENTS

General Notes	Page 11	Spillage Monitoring System	Page 23
Important Notes	Page 11	Error Codes	Page 24
Positioning the Logs	Page 12	Cleaning	Page 28
Stove Controls	Page 13	Servicing	Page 28
Operating The Stove	Page 16	Guarantee	Page

GENERAL NOTES

- This stove has been individually designed to add charm and character to your home. Providing a highly efficient heat source, the stove has the look and charm of a wood burning stove coupled with the convenience of clean burning gas.
- Due to the newness of materials the stove may give off a slight smell for a period of time after commissioning. This is quite normal and any odours should disperse after a few hours operation.
- A remote is not supplied with manual stoves, as such all references to remote operation can be ignored by owners of manual stoves.

IMPORTANT NOTES

- The installation must be in accordance with National Regulations and must be carried out by a qualified installer. Under no circumstances should the appliance be operated with the door open, without the door attached or the door glass damaged broken or missing.
- All surfaces except the control unit are considered to be working surfaces. Most parts of the stove will get hot during and after use. If young children, the elderly or infirm are likely to be near the stove, then a suitable fireguard to BS8423 is recommended.
- Do not drape clothes, fabrics or other combustible materials over the stove.
- Curtains must be at least 400mm above the top of the stove.
- A combustible shelf may be fitted over the appliance provided that in the case of a 150mm or less deep shelf there is at least 400mm clearance above the top of the stove.
- The stove should not be used for any other purpose than as a room heater and a decorative stove

- When starting the fire the burner usually take around 1 to 10 seconds to ignite and adjust to the maximum power setting. This can take longer on the first lighting as it has to clear out any air locks, also if it is an LPG burner and has been stood unused for time, the gas could have settled in the pipework and again this could take longer.

POSITIONING THE LOGS

The logs should only be arranged as detailed below and by a qualified person.

The stove must only be fitted with the ceramics supplied. DO NOT use any extra logs or coals.

1. Slacken the screw securing the door handle and open the stove door.
2. Position the back board into the burner tray ensuring that it is correctly seated behind Tab A and that the flame strip is not obstructed (Fig 6).
3. Locate LOG1DMR and LOG2DMR into position on the back board as shown (Fig 7).
4. Locate LOG3DMR into position as shown (Fig 8)
5. Locate LOG4DMR into position as shown (Fig 8)
6. Close the stove door.
7. Tighten the door locking screw.

Fig.6



Tab A

Fig.7



LOG2DMR

LOG1DMR

Fig.8



LOG4DMR

LOG3DMR



Under no circumstances should the stove be operated with the door open, without the door attached or the glass in the door damaged, broken or missing

WARNING

STOVE CONTROLS

This stove is fitted with a gas valve which can be operated via the control unit located behind the right hand foot of the stove, or using the remote control if supplied.

Fig 9 - Control unit

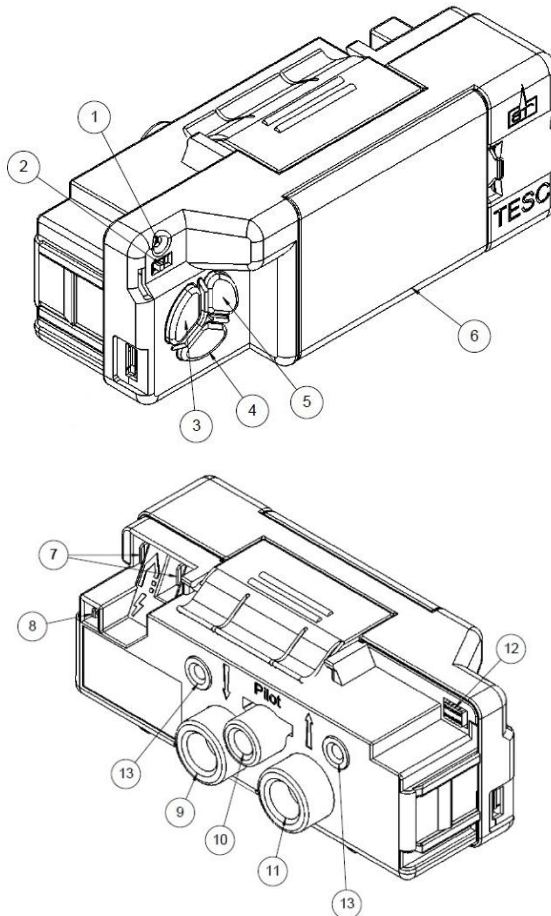

- 1 Red indicator LED:**
 - OFF:** Burner is in standby and ready for start, or already in continuous operation
 - Fast flashing:** Control unit is busy and will not accept commands.
 - Medium fast flashing:** Control unit is preparing a (re)start of the burner.
 - Slow flashing:** Control unit is detecting an error.
 - One short flash every 8 seconds:** Low battery warning.
 - Always ON:** Burner is locked.
- 2 Master switch:**
 - Left position:** Control unit is disconnected from all power supplies and does not consume power.
 - Right Position:** Control unit is powered and ready to operate.
- 3 (-) Button:**
 - Burner in operation:** Use this button to reduce the power level.
- 4 ON/OFF Button:**
 - Burner in operation:** Use this button to stop burner operation.
 - Standby:** Use this button to start burner operation.
 - Burner locked:** Use this button to unlock the burner and to reset from error state.
 - If control unit is preparing to restart:** Use this button to stop the restart and disable further automatic starts.
- 5 (+) Button:**
 - Burner in operation:** Use this button to increase the power level.
- 6 Battery box:**

Insert here 3x AA-type Alkaline batteries.
- 7 Thermocouple connector.**
- 8 High voltage and flame sensing output.**
- 9 Gas inlet.**
- 10 Pilot burner outlet.**
- 11 Main burner outlet.**
- 12 TTB connection socket.**
- 13 Control unit mounting points.**

Fig 10 – Remote Control Handset

Grasp around the handset covering the back and sides to unlock its functions. The green unlock light will illuminate to show when the handset is unlocked and ready to accept commands. (N.B. Keep a grip of handset to keep it unlocked, to continue to operate the command buttons).

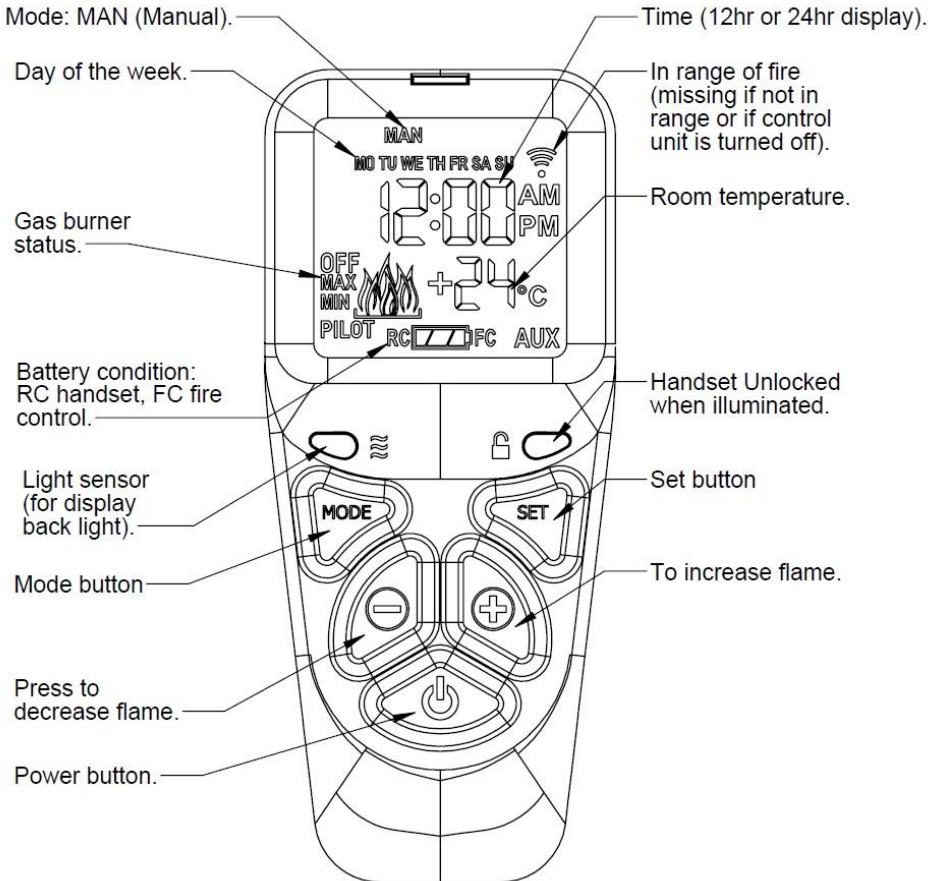

Quick start user instructions

Manual control unit

The control unit is situated on your fire. Figure 8 shows the main features of the control.

The control requires 3 AA size alkaline batteries to be inserted under the battery compartment cover. The orientation of these is shown moulded into the battery compartment.

After fitting the batteries and replacing the cover the fire can now be operated.

Slide the Master switch to the right to the ON position (I symbol).

To start the fire, press the ON/OFF button and hold for 1 second then release. The burner will within around 1 to **10** seconds ignite and adjust to the maximum power setting,

The power of the burner can be adjusted up and down by pressing the + and - buttons.

To stop the fire, simply press the power button again and the burner will stop.

NOTE: For safety reasons a button must be pressed and released for the command to be recognised. Keeping hold of a button when pressing (unless otherwise instructed) will not be recognised as a command press.

Remote control handset

Figure 9 shows the main features of the Remote control handset

The remote control handset requires 2 AA size alkaline batteries to be inserted under the battery compartment cover. The orientation of these is shown moulded into the battery compartment.

To start the fire, with one hand grasp around the rear and both sides of the button area control. The green unlock light will illuminate.

Keep the handset held to keep the control unlocked, to enable operation of the buttons.

Then with the other hand touch and hold a finger on the power button for about 3 seconds. A short beep and a flash of the unlock light will happen.

When the word “pilot” appears at the bottom left hand corner of the display, immediately release the power button.

A second flash of the unlock light and a longer beep will also sound at the time to release the power button.

The Fire should be lit within a few seconds.

If power button is held for more than a few seconds after second flash/beep/word pilot appears, the command is ignored for safety reasons.

Similarly if it is released too soon before the word pilot appears, the command is also ignored.

With this system, the control has been designed to ensure that only intended ignition of the fire occurs.)

To stop – with handset held to unlock it, press then release power button.

Detailed user instructions

Setting the Remote control handset

Upon successful insertion of the batteries in the Handset the display will be as shown right.

The handset will be supplied paired to the fire and all that is required is to set the time of day and select if a 24h hour clock or 12 hour clock display is required and if temperature display is on Celsius or Fahrenheit.

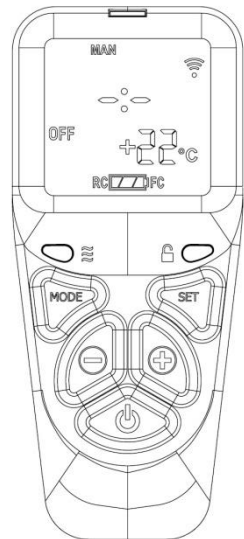

Setting the time

Holding the handset as described previously to unlock the keypad, press and hold “SET” for a few seconds and the display will be as shown.

Setting the display for 12 or 24 Hour display

As always when pressing the remote control buttons keep the control held to keep the green light on and therefore handset safety feature, unlocked. The H indicates that it is time to set the timer to either 24 hour display or 12 Hour (AM or PM) display. Press the + or – button on the handset to toggle between the two settings. When you are ready to confirm the setting you want press the “SET” button to progress to setting the day of the week.

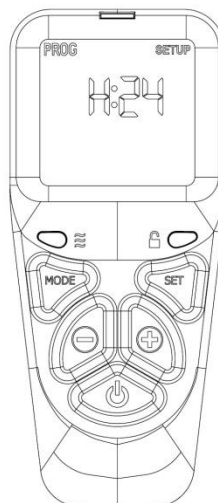

Setting the day of the week

Press and release the + and – buttons until the correct day of the week is shown on the display.
(Mo = Monday, Tu = Tuesday, We = Wednesday, Th = Thursday, Fr = Friday, Sa=Saturday and Su=Sunday).

Press “SET” to accept the day of the week and to progress to setting the Hour of the day.

Note: Whilst doing this setup pressing “SET” advances to the next display and pressing “MODE” will return you to the previous display setting.

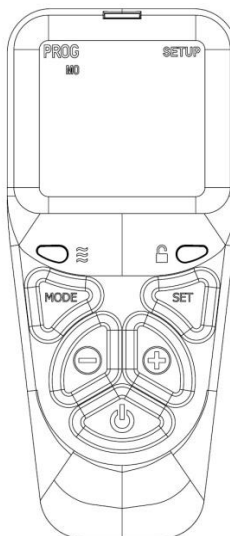

Setting the Hour

Press and release the + or – button to change the hour to the correct hour and press set to store and to move to setting the minute. Repeat this for setting the minutes.

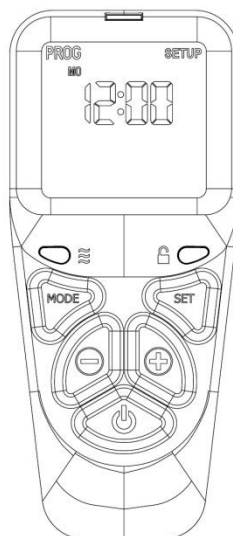

Setting the temperature display to Celsius or Fahrenheit.

Press and release the + or - button to toggle between °C and °F.

When the display shows the desired symbol, press the SET button to store the setting.

As the important settings above have now been done. Press and hold (not releasing straight away) the "SET" button for a few seconds and this will exit the setup menu.(alternatively you can press and release the set button several more times until the time of day is displayed on the handset.

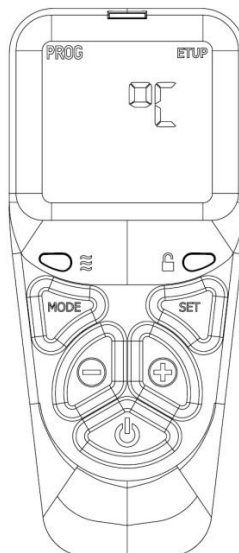

The control is now ready for use with the Fire Control.

Note: the legend at the bottom shows the battery condition of both the batteries in the hand set and in the fire control alternately. RC = Remote Control handset and FC = Fire control.

The control is designed to get the most out of the batteries but when eventually the display shows they are spent (when the battery legend is an empty area, we recommend you change the batteries in the handset before they are flat, to avoid having to reprogram the time of day in again. N.B. Pairing is not lost, even if the batteries are removed or flat. The pairing is not lost when the batteries are flat but replacing them quickly before they have gone flat will avoid having to set the time of day, day of the week again)

Paging the handset

If you have misplaced the handset (and it is in range of the fire), you can page it by pressing the + button only on the Control unit for around 5 seconds.

The handset will flash and make a noise to help you to locate it.

Once you pick up and grasp the handset to unlock it, the Control unit will detect this and so the sound stops.

The flashing and sound will last for 60 seconds each time the handset is paged as described. If not found in 60 seconds, page again and so on.

NOTE: PRESS “+” Button ONLY, NOT + and - Together as you will accidentally break the handset pairing and have to reset handset to factory state and pair again (see the pairing handset section if this happens).

Subsequent hand set pairing

Display handset

The handset should be supplied already paired with your fire, however if it becomes necessary to cancel the pairing and re pair it again do the following steps below. (NOTE: A new pairing can be accidentally started by accidentally pressing the plus and minus buttons together at the same time on the Control unit and held for 5 seconds.

Factory Reset of display handset

(To enable handset to be paired again) To reset a handset to factory conditions to enable it to be paired with a control.

- Hold the handset to unlock. Press and hold set until handset beeps and release the set button. PROG will be at the top left corner.
- Press and release the mode button until the word SETUP is flashing in the top right corner.
- Press and release SET to enter the SETUP menu.
- Press and release the set button around 9 times until you see CA0 on the display.
- Press then release the + (or – button) to change the display to CA1 and press and release the SET button again.
- The word TESC will appear in the window to show that this handset is now reset and ready to pair again.

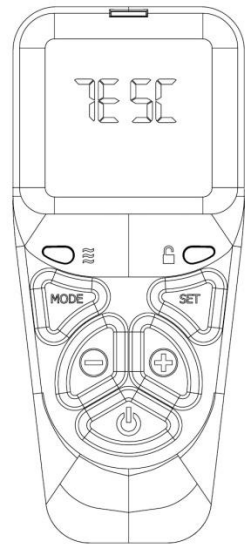

WARNING

The handset is paired originally in the factory follow instructions over leaf only if handset is unpaired or replaced

Pairing the handset to the Fire control unit

With 2 good quality AA alkaline batteries in the handset in the direction shown inside, if the handset can be paired with a control, it will have the display with the word TESC on the display as shown over leaf.

The handset must be within 1 metre (3 feet) of the fire when pairing

After fitting the batteries and with the **power** isolator slide switch on the Control unit slide to the on position (I), simultaneously press and hold the – and + buttons on the Fire control unit (i.e. not the handset) until the red light comes on. Then immediately release the buttons and press the ON/OFF button on the Control Unit. The handset makes a noise and the display shows the pattern as shown to the right.

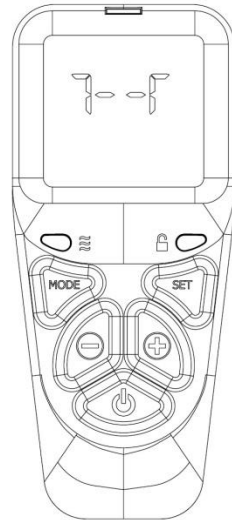

Hold the handset in one hand so your fingers wrap around the back of the operating buttons area of the handset. A green unlock light will illuminate when the handset has detected your hand. The green light must be illuminated in this way for any of the command buttons to accept commands to operate the fire control.

While the display is as shown, and holding the handset as described, press the SET button with the other hand to finish off the pairing of the handset to the Fire Control. You can then enter the setup and set the time of day on the handset. As shown earlier in the instruction N.B. If the display returns to the one shown above with the word “TESC” shown, then too much time has passed before pressing “SET” and so the handset has not paired yet. Simply repeat pairing again.

N.B. Only ever press + and - buttons together when pairing handsets. If done afterwards this will break the pairing made and a factory reset of the handset will need to be performed See **Factory Reset of display handset**

Thermostatic Mode

Thermostatic mode will allow you to set a desired temperature for the stove to maintain. Once the temperature is reached the fire will reduce the power to minimum and regulate itself to maintain the temperature.

The timed thermostat can be set before or during manual operation of the fire.

Hold the handset to unlock as described previously and press the mode button as many times as necessary until the THERMOSTAT symbol is flashing at the top of the display.

Press and release the set button and this will put the control into Thermostat mode.

The Sun, Moon or Frost symbol will on the left hand side of the screen depending on the time of day and temperature.

Press and release the set button to access the temperature control. You can adjust the temperature using the + or – buttons.

After adjusting the temperature press set again to enter the setting required (or if left for a few seconds this time is now stored and used).

If the fire is lit this will then adjust the power settings to reach and maintain the temperature. If the stove is not lit, Press and hold the ON/OFF button for 3 seconds (A short beep and a flash of the unlock light will happen. When the word “pilot” appears at the bottom left hand corner of the display, immediately release the power button). The fire will now light and adjust the power settings to reach and maintain the set temperature.

SPILLAGE MONITORING SYSTEM

The stove is fitted with a spillage monitoring system which senses any excess temperature due to a flue restriction or blockage. In this event the gas supply is automatically turned off.

Should this occur then slide the Fire control unit isolator switch to **OFF (0)** position and wait approximately 10 minutes for the switch to automatically reset. Re-light the stove as described in OPERATING THE STOVE section (page 15). If the stove repeatedly shuts itself off, DO NOT use the stove and have the flue system checked by a qualified person.

This spillage monitoring system is not adjustable and must not be put out of action.

ERROR CODES

The Control unit is NOT faulty just because it shows an Error code. The Error code can be read when a wireless Control unit is paired with a Wireless enabled Remote control. The Error Code is there to enable servicing to identify what may be happening to the Control unit to cause the fire not to operate correctly. This is most likely to be environmental or one of the other components that are connected to the Control unit.

If an E code is displayed, allow the fire to cool and perform a normal start attempt to reset the control to standby. Then perform a normal start attempt again to see if the fire has cleared the error and the fire is functioning correctly.

If the ERROR does not clear, it is essential before undertaking any actions on the servicing as detailed below, that the batteries being used are good and should be replaced with new ones to be sure that is not the problem. Faulty batteries can cause false error codes. New batteries can be faulty too. ALWAYS CHANGE ALL THE BATTERIES TOGETHER AND NOT JUST ONE OR TWO AND ALWAYS OF THE SAME MAKE AND TYPE (I.E MANUFACTURER AND MODEL TYPE).

The battery contact must be clean and there must not be any leakage from any batteries in the battery compartment or on the battery contacts. Clean thoroughly if found, they must be spotlessly clean.

After replacing the batteries, to clear the error code perform a start cycle by pressing the start button as normal. Then press again in the same way to attempt a new start cycle. The error code must be cleared for the fire to function correctly.

Servicing must only be carried out by competent personal that have current qualifications and accreditation (i.e. Gas safe).

Code	Comment	Appearance	Possible Cause	Action
E00	TESC locked due to failed ignition	Red Led is permanently on on TESC unit (and E00 on handset, if used).	Temporary air disturbance around pilot burner	Reset control by pressing start button for 1 second and releasing. Then press again the same way to attempt a normal start command. Repeat up to 10 times as necessary to see if this overcomes the issue as it may resolve itself eventually.
			No gas on appliance inlet	Check to see if gas is present at gas appliance inlet. (Check gas supply is on, that gas line purged of air and the supply pipework is free of blockages or contamination)
			Pilot contaminated with lint or other materials	Clean the pilot free of any dirt, dust carbon granules or lint, especially around the brass body of the bunsen burner and its gas and electrical connection and the area around the flame ports and the spark plug and electrode tip. Check the electrode gap is 3—4mm.
			No Spark at Electrode (fire not igniting pilot burner)	Check ignition cable for damage and listen and watch for tracking out of spark to see if it is present but not making it to the electrode tip on the pilot burner.
			Pilot pipe or pilot injector could be blocked	Clear pipe and consider changing pilot
E01	Low current from thermocouple but flame: possibly CO alarm	Flashing Red LED on TESC Control	Inlet pipe contaminated Pilot pipe blocked -- no gas reaching pilot burner Chimney blocked causing Co / Co2 to build up in the reobuild Pilot thermocouple defective/old Possible temporary air disturbance on pilot flame	Clean out and clean TESC control of contamination. Check pilot pipe, check flame appearance of pilot flames Check flue Change pilot or thermocouple Clear error and restart to check ignition ok
E02	Too high ambient temperature (>73°C) around control		Negative flue pull or blocked flue or similar	Occurs if stratified ok but shuts down when fire heats up. Check for flue problems. Fire cuts out to prevent over heating
			Blocked flue	Check and clear
			Poor position of Ceramic parts	Check manual for correct placement
E03	No, defective, or bad connected thermocouple		Bad connection	Check if connected correctly and terminations are sound
			Defective thermocouple	Replace pilot
			Thermocouple not connected to correct terminal or reversed polarity	Connect thermocouple
E04	False flame signal		Occurs during stopping fire	Reset and try again. Reset and try again. Reset and try again. Reset and try again. Reset and try again.

E05	False flame signal		Flame sensing on pilot before start of ignition sequence or after valve has shut off. Contamination of electrode to ground	Check if and clean around the area of the pilot for lint and other contamination and clean. Check where the thermocouple connect to the TESC control for the same contamination. Clean these areas.	Reset and try again.
E06	Too low voltage on powersupply to start the burner		Weak or old or defective batteries or contaminated contacts	Clean contacts and replace batteries	Reset and try again.
E07	Power supply breakdown during peak current consumption		Check/change all the batteries or check power adaptor. .Note always change all batteries together never only 1 or 2	Replace batteries/power adaptor/ check that contacts are clean	Reset and try again.
E08	Error caused by external pressure switch		Check the pressure switch	Replace if necessary	Reset and try again.
E09	Error caused by external pressure switch		Check to see if jumpers are in 30 way connector		Reset and try again.
E10	Error caused by external pressure switch		Pressures switch action connection or jumpers missing or not connected properly	Check pressure switch connections, check to see if jumpers are in place on back of TESC.	Reset and try again.
E13	Wired thermostat is out of tolerance		Pressures switch action connection or jumpers missing or not connected properly	Check pressure switch connections, check to see if jumpers are in place on back of TESC.	Reset and try again.
E14	Button (+) sticks either on TESC or on wired control panel (if used)		Check wiring and thermostat	Check switch for damage, contamination across terminals or damaged wiring. Disconnect wired thermostat if fitted and try a start, if it works replace thermostat	Reset and try again.
E15	Button (+) is shorted to other buttons either on TESC or on wired control panel (if used)		Check for contamination around buttons	Clean as necessary. Replace switch panel as necessary if damaged or too contaminated. Disconnect wired control panel and try again – if it works replace wired control panel	Reset and try again.
E16	Button (ON/OFF) is shorted to other buttons either on TESC or on wired control panel (if used)		Check for contamination/damage and replace wired switch panel if necessary	Clean as necessary. Replace switch panel as necessary if damaged or too contaminated. Disconnect wired control panel and try again – if it works replace wired control panel	Reset and try again.
E17	Button (+) is shorted to other buttons either on TESC or on wired control panel (if used)		Check for contamination/damage and replace wired switch panel if necessary	Clean as necessary. Replace switch panel as necessary if damaged or too contaminated. Disconnect wired control panel and try again – if it works replace wired control panel	Reset and try again.

E18			Failure during setting control to standing pilot	Probably a 1 off event, Reset and try again	Reset and try again.
E20	Software corrupted		Damaged from environment	Try to reset and restart	Reset and try again.
E21	Tried to config a TESC as Clusterslave while a wired thermostat is connected		Factory assembly warning on setup configuration not a maintenance error	Usually only a factory assembly error. Could happen if done in error in servicing.	Reset and try again.
E22	Tried to calibrate TESC with TESC easystest while a wired thermostat is connected		Not field error	Disconnect thermostat before attempting using easystest unit.	Reset and try again.
E23	Warning: end of life is near, should be replaced soon		Not field error	Indicated that control has performed a high number of operations and so fire should be serviced and control replacement should be considered as preventative maintenance (should not really occur before 10 years from new).	Reset and try again.
E24	Thermocouple doesn't reach final current -- damaged or aged		Replace Pilot	Check and correct Thermocouple wiring. Replace thermocouple if necessary	Reset and try again.
			Check pilot connections	Check and correct Thermocouple wiring. Replace thermocouple if necessary	Reset and try again.
E26	Defective or wrong wired USB-power supply		Pilot pipe may be blocked completely	Clear pipe, replace pilot as necessary	Reset and try again.
E48	Short circuit on thermocouple, or thermocouple reversed polarity		Try again and if repeatedly fails replace	Replace with new USB power supply of the correct type.	Reset and try again.
E49	False flame signal		Wrongly wired	Check and correct Thermocouple wiring. Replace thermocouple if necessary	Reset and try again.
E50	Error		Flame detected during operation of fire when it should not be detected --- contamination of electrode circuit to ground	Check if and clean around the area of the pilot for lint and other contamination and clean. Check where the thermocouple connect to the TESC control for the same contamination. Clean these areas.	Reset and try again.
E51	Error caused by external pressure switch		Flame detected during operation of fire when it should not be detected --- contamination of electrode circuit to ground	Check if and clean around the area of the pilot for lint and other contamination and clean. Check where the thermocouple connect to the TESC control for the same contamination. Clean these areas.	Reset and try again.
All other E numbers	Error			Check pressure switch connections, check to see if jumpers are in place on back of TESC. Allow fire to cool for 30 minutes and then reset and try again. Reset for 10 times and try again to see if it clears the Error.	Reset and try again. Reset and try again.

CLEANING

Ensure that the stove is turned off before cleaning and is cold.

DO NOT use abrasive cleaning agents.

The stove is supplied with ceramic logs that should only be cleaned and arranged by a qualified person in accordance with the Installation Instructions.

SERVICING

It is essential that the stove is regularly serviced, and the flue system checked by a qualified person.

Servicing Instructions

The stove is fitted with a spillage monitoring system consisting of a thermal switch connected to a thermocouple interrupter. This system is not adjustable and must not be put out of action. If any parts of the spillage monitoring system require replacement only original manufacturers' parts must be used.

The thermal switch rating is 120°C. Quote this rating if ordering a new switch.

1. The following servicing procedure should be carried out regularly and only by a qualified person.
Ensure that the fire is turned off and is cold.
2. If fitted, remove the screw securing the door handle and open the stove door.
3. Remove the ceramics in the reverse order to that described in POSITIONING THE LOGS section (p.8 or 12).
4. Remove and deposition of dirt, lint etc. carefully from the burner flame strip, tray and pilot assembly with a soft brush.
5. Due to the intense temperatures reached in the fire, some surface cracks may appear on the ceramic components. This is quite normal and will not affect the safe operation of the fire.
Replace the ceramics as described in the POSITIONING THE LOGS section (p.8 or 12).
6. Close the stove door; replace the screw securing the door handle or door.
7. Check the supply pressure as described in the TECHNICAL INFORMATION section (p.3).
8. Ensure correct operation of the flue as described in CHECK FOR SPILLAGE section (p.9).

9. GUARANTEE

CONDITIONS OF GUARANTEE

Your ESSE is guaranteed against defects arising from faulty manufacture for 2 years when supplied by an ESSE Specialist.

Upon registration of the warranty, ESSE will extend the guarantee period to 5 years from purchase. Your details must be registered with us by either returning the completed warranty card or by completing registration on-line at www.esse.com. The warranty must be registered within 1 month of installation to qualify for the 5 year warranty.

The appliance must be only used for normal domestic purposes and in accordance with our instructions, be correctly installed and serviced.

The guarantee does not cover:

Installation

Wear and tear

Parts deemed to be replaceable or service parts including electrical components that may be replaced during the normal usage of the appliance.

Enamel damage caused by impact, spillage, water ingress or condensate attack from flue or by using unsuitable fuels.

This guarantee is personal to the original purchaser and not transferable.

Any stove or defective part replaced shall become the Company's property

HOW TO PROCEED WITH A COMPLAINT

If you have cause for dissatisfaction with your stove, you should first contact your ESSE dealer, who will bring your concerns to our attention. We will assess the nature of the complaint and either send replacement parts for your dealer to fit, or arrange for an ESSE engineer to inspect the appliance and carry out any work that may be deemed necessary. If the fault is not actually due to faulty manufacture but some other cause i.e. misuse, failure to install correctly, or failure to service at regular intervals, a charge will be made to cover the cost of the visit and any new parts required.

SPARE PARTS

Only genuine ESSE spare parts are recommended.



ESSE Engineering Limited, Ouzledale Foundry, Long Ing, Barnoldswick, Lancashire

BB18 6BJ

Tel. 01282 813 235, **Fax:** 01282 816 876

Website and On-line Store <http://www.esse.com>